

PTB

Fachorgan für Wirtschaft und Wissenschaft

Mitteilungen

Mass and Derived Quantities



Fachorgan für Wirtschaft und Wissenschaft
Amts- und Mitteilungsblatt der
Physikalisch-Technischen Bundesanstalt
Braunschweig und Berlin

Special Issue

Volume 118 (2008) No. 2 and No. 3

Contents

Mass and Derived Quantities

- *Roman Schwartz, Michael Gläser*: Mass and Derived Quantities 3
- *Michael Gläser*: Redefinition of the Kilogram 5
- *Michael Borys, Frank Scholz, Martin Firlus*:
Realization of the Mass Scale 10
- *Horst Bettin, Michael Borys, R. Arnold Nicolaus*:
Density: From the Measuring of a Silicon Sphere to Archimedes'
Principle 16
- *Roman Schwartz, Panagiotis Zeroos, Oliver Mack, Karsten Schulz*: Mass
Determinations and Weighing Technology in Legal Metrology 23
- *Rolf Kumme, Jens Illeemann, Vladimir Nesterov, Uwe Brand*:
Force Measurement from Mega- to Nanonewton 33
- *Michael Kobusch, Thomas Bruns, Rolf Kumme*:
Dynamic Calibration of Force Transducers 42
- *Dirk Röske*: Torque Measurement: From a Screw to a Turbine 48
- *Dirk Röske*: Multi-component Measurements of the Mechanical
Quantities Force and Moment 56
- *Wladimir Sabuga*: Pressure Measurement from Kilo- to
Gigapascal 60
- *Karl Josten*: The Quantity of "Nothing":
Measuring the Vacuum 65

Title picture:

The original kilogram in Paris is no longer what it once was. This platinum-iridium cylinder appears to be losing mass – this is indicated by comparison measurements with the national kg prototypes. A possible way to replace the original kilogram with a more fundamental definition is pursued in the international Avogadro project under the

direction of PTB. With a sphere made of a silicon crystal, scientists want to trace back – by "counting" the atoms in the crystal – a macroscopic mass to the atomic mass and thus lay the foundation for a redefinition of the kilogram.

Photo: Marc Steinmetz/VISUM

Imprint

The *PTB-Mitteilungen* are the metrological specialist journal and official information bulletin of the Physikalisch-Technische Bundesanstalt, Braunschweig and Berlin. As a specialist journal, the *PTB-Mitteilungen* publishes scientific articles on metrological subjects from PTB's fields of activity. As an official information bulletin, the journal stands in a long tradition which goes back to the beginnings of the Physikalisch-Technische Reichsanstalt (founded in 1887).

Publisher

Wirtschaftsverlag NW
Verlag für neue Wissenschaft GmbH
Bürgermeister-Smidt-Str. 74–76,
27568 Bremerhaven
Postfach 10 11 10, 27511 Bremerhaven
Internet: www.nw-verlag.de
E-mail: info@nw-verlag.de

Editor

Physikalisch-Technische Bundesanstalt (PTB),
Braunschweig und Berlin
Postal address:
Postfach 33 45, D-38023 Braunschweig
Delivery address:
Bundesallee 100, D-38116 Braunschweig

Editorial staff/Layout

Press and Information Office, PTB
Dr. Dr. Jens Simon (Editor in Chief)
Gisela Link
Tel.: +49 531 592-82 02
Fax.: +49 531 592-30 08
E-mail: gisela.link@ptb.de

Translation

PTB-Sprachendienst (PTB Translation Office)
U. Baier-Blott
C. Charvieux

Reader and subscription service

Marina Kornahrens
Telefon: (04 71) 9 45 44-61
Telefax: (04 71) 9 45 44-88
E-mail: vertrieb@nw-verlag.de

Advertising

Karin Drewes
Telefon: (04 71) 9 45 44-21
Telefax: (04 71) 9 45 44-77
E-mail: info@nw-verlag.de

Frequency of publication and prices

The *PTB-Mitteilungen* are published four times each year. An annual subscription costs Euro 55.00, one issue costs Euro 16.00, plus postage costs. The journal can be obtained from bookshops or from the publisher. Cancellations of orders must be made to the publisher in writing at least three months before the end of a calendar year.

© Wirtschaftsverlag NW, Verlag für neue Wissenschaft GmbH, Bremerhaven, 2009

All rights reserved. No part of this journal may be reproduced or distributed without the written permission of the publisher. Under this prohibition, in particular, comes the commercial reproduction by copying, the entering into electronic databases and the reproduction on CD-ROM and all other electronic media.

Mass and Derived Quantities

Roman Schwartz¹, Michael Gläser²

Mass and its derived mechanical quantities belong to the most important measurands in trade, economy, industry and research. Besides mass itself – or “weight”, as it is usually called in everyday life – the other main quantities which belong to this group are force, pressure, density and torque.

In commercial transactions, the price of most goods is billed according to their mass or their volume. Density is another important quantity for the determination and billing of volumes of static or flowing liquid or gaseous goods. In climate research, density differences in ocean water are decisive for the global ocean currents. Force measurement plays an important role in mechanical engineering and numerous safety-related areas, such as materials testing, surveillance of oil platforms or structural monitoring. Torque measurements are used for all rotating machines, such as electric motors, combustion engines or turbines, but also in screwing technology. Gas pressure measurements are used in the case of barometers for air pressure, for the surveillance of containers filled with gases for technical purposes and in vacuum apparatuses. In everyday life, we encounter this when we check the air pressure in our car tyres. The pressure of liquids is measured for pumps, for hydraulic facilities, and in the medical field, e. g. for blood pressure. Pressure measurements are of great importance in numerous industrial applications, especially in the field of safety and process metrology.

This special issue of the PTB Bulletin (“PTB-Mitteilungen”) is dedicated to all these measurement quantities. It starts with an overview of the most important fields of application for each mechanical quantity and describes the state-of-the-art of the realisation and dissemination of the respective unit in the International System of Units (SI) by means of so-called “standard measuring facilities” and identifies the current focal points of research and future developments.

In this context, it is obvious that the discussion on the “Redefinition of the Kilogram” must be mentioned. In the section dedicated to this particular topic, the current experiments are described which may contribute to linking up the kilogram to a fundamental constant, such as the Avogadro constant or Planck’s constant. It is planned to define the value of one of these constants in a future redefinition, just as in the metre definition of 1983, the value of the speed of light was defined. Also, the current status of the discussions in the Consultative Committees (CCs) of the Meter Convention is reported.

The article “Realisation of the Mass Scale” presents the hierarchy of the mass standards and describes how mass standards and weights of the sub-multiples and multiples of the kilogram are derived from or traced back to the national prototype of the kilogram. The importance of the correction for air buoyancy and of the weighing instruments and mass comparators used are dealt with in particular.

The article “Density: From the Measuring of a Silicon Sphere to Archimedes’ Principle” describes how the density of solids and liquids is measured. For numerous applications, it is essential to know the density, to be able to determine the volume on the basis of which the price of flowing liquids or gases is calculated. The determination of the mass and volume of silicon spheres as the most accurate density standards, the dissemination of the unit of density by means of hydrostatic comparative methods, and questions as to the long-term stability of these standards are also dealt with.

The article “Mass Determinations and Weighing Technology in Legal Metrology” gives an overview of the present palette of automatic and non-automatic weighing instruments in use for commercial transactions and in numerous industrial areas, as well as of the legally prescribed requirements and tests as a pre-condition for a

¹ Dr. Roman Schwartz, Head of the Division “Mechanics and Acoustics”, e-mail: roman.schwartz@ptb.de

² Dr. Michael Gläser, former Head of the Department “Solid Mechanics”, e-mail: michael.glaeser@ptb.de

type approval. Recent European developments and international agreements and directives for weighing instruments and load cells are also discussed.

The article "Force Measurement from Mega- to Nanonewtons" deals with a field of static force measurement in which very diverse measuring principles are applied. For the range "high forces" from approx. 1 N to 2 MN, facilities are described which use the weight force of deadweights for the direct generation of force with highest accuracy. For even higher forces up to approx. 16 MN, other measuring principles are used, especially the amplification of force by means of hydraulic or lever amplifications. In the mN range, on the contrary, the principle of electromagnetic force compensation is applied – similar to the case of precision balances. For smallest forces in the nN range, other, indirect methods are used.

The article "Dynamic Calibration of Force Transducers" deals – in contrast to the previous article – with force as a time-dependent quantity as is the case, for example, with periodic forces and impact forces as they are found, amongst others, in materials testing, crash tests in the automotive industry or satellite testing in the aerospace industry. The particular requirements which must be placed on force transducers for dynamic forces are explained.

The article "Torque Measurement: From a Screw to a Turbine" first clarifies the difference between "pure" torque and the terms of force and torque as they often overlap in everyday practice. Motionless static torque (pre-condition for most accurate measurements), rotating

static torque and, finally, dynamic torque are presented. The article concludes with the standards for calibration and the metrological torque infrastructure.

The article "Multi-component Measurements of the Mechanical Quantities Force and Moment" describes a measurement method which has been newly developed at PTB since it was necessary in force and torque measurements to metrologically detect the disturbing quantities. This method allows the components of, in total, six degrees of freedom to be generated and measured independently of each other.

The article "Pressure Measurement from Kilo- to Gigapascal" deals with the realisation and dissemination of the quantity pressure of gases and liquids, including the most important measuring instruments for this purpose. Starting from the traditional method of pressure measurement, i. e. with the aid of liquid columns, pressure balances, aneroid barometers and other measuring instruments working in a range from 25 Pa to approx. 360 GPa are presented.

The last article, "The Quantity of 'Nothing': Measuring the Vacuum", describes pressure measurements down to 10^{-12} Pa. Vacuum techniques are presently used in numerous industrial processes, such as microelectronics, surface coating for the finishing of surfaces, in the food industry and in research. The methods applied for different pressure ranges and their link-up with SI units are described.

We would like all our readers to gain a lot while leafing through these articles about "Mass and Derived Mechanical Quantities"!

Redefinition of the Kilogram

Michael Gläser*

1 Introduction

The kilogram is the only one of the seven base units of the International System of Units (SI) which is still defined by a material measure – the international prototype of the kilogram. The other base units are defined by reference to a fundamental constant of physics or by an experimental procedure. Some – additionally – depend on other base units. The metre, for example, is defined as the length of the path travelled by light in vacuum during a certain fraction of the second, on the basis of a fixed value of the speed of light. Thereby, reference is made to the second as the unit of time. The definition of the ampere describes an idealised arrangement of two conductors and thereby indicates the values of measurands in the units “kilogram”, “metre” and “second”. By means of these values, also the magnetic field constant μ_0 is defined.

For approximately 30 years, experiments have been carried out to also link the kilogram to the value of a fundamental constant. These are Planck’s constant and the Avogadro constant or the atomic mass unit. Two types of these experiments have meanwhile progressed so far that a redefinition of the kilogram seems probable within the next few years. The decision-making bodies agree on the matter that a relative uncertainty of few parts in 10^{-8} and a corresponding agreement of the relevant experiments are a precondition for a redefinition.

Besides a redefinition of the kilogram, redefinitions of the ampere, the kelvin and the mole are envisaged. Whereas for the redefinition of the kelvin we are still waiting for sufficiently accurate results, it is planned to resort, for the ampere, to known facilities which are already in use for practical standards based – for the volt – on the Josephson effect and – for the ohm – on the quantum Hall effect. For the mole, the current definition is intended to be re-formulated in such a way that it is based on fixing the value of the Avogadro constant, without reference to the unit “kilogram” – as is the case with the current definition.

2 The experiments

The first experiments for a redefinition of the kilogram started as early as the 1970s: the

Avogadro Experiment with a silicon single crystal at the National Institute of Standards and Technology (NIST – previously NBS, USA) [1] and the watt balance at the National Physical Laboratory (NPL, UK) [2, 3].

After that, a watt balance was also set up at the NIST [4, 5] with which, in 2007, the most accurate value ever of Planck’s constant was measured (relative uncertainty: $3.7 \cdot 10^{-8}$) [6]. In 2007, the NPL published a result with a relative uncertainty of $6.7 \cdot 10^{-8}$ [7]. Further watt balance experiments are in the process of being set up or are currently in a test phase [8]: since 1997, at the Bundesamt für Metrologie (METAS, Switzerland), since 2000, at the Laboratoire National de Métrologie (LNE, France) and since 2002, at the Bureau International des Poids et Mesures (BIPM, France). The Chinese and the New Zealand metrology institutes, too, are planning to develop a watt balance.

At the PTB, measuring the Avogadro constant has been possible since the end of the 1970s through the setting-up of an X-ray interferometer for the measurement of the lattice constant in the silicon single crystal. Also other institutes, such as the Istituto Nazionale di Ricerca (INRIM – previously IMGIC, Italy) and the National Metrology Institute of Japan (NMIJ/AIST – previously NRLM, Japan) followed suit. The Institute for Reference Materials and Measurements (IRMM, Belgium) participated by measuring the abundances of the three isotopes ^{28}Si , ^{29}Si and ^{30}Si in natural silicon. Lately, the National Metrology Institute of Australia (NMI-A – previously CSIRO) has taken on the production of silicon spheres. The result for the Avogadro constant was last made public in 2005, with a relative uncertainty of $3.1 \cdot 10^{-7}$ [9]. Other institutions and companies are participating in the International Avogadro Project – launched only a few years ago – with highly enriched ^{28}Si . A new and more accurate result is expected at the end of 2009.

Another approach was pursued with the volt balance, which led to results with relative uncertainties of approx. $3 \cdot 10^{-7}$ [10,11] at PTB and CSIRO. This approach was, however, not pursued any further since an improvement could not be expected with reasonable effort. Also the experiment “Magnetic Levitation” of the NMIJ

* Dr. Michael Gläser, former head of the Department “Solid Mechanics”, e-mail: michael.glaeser@ptb.de

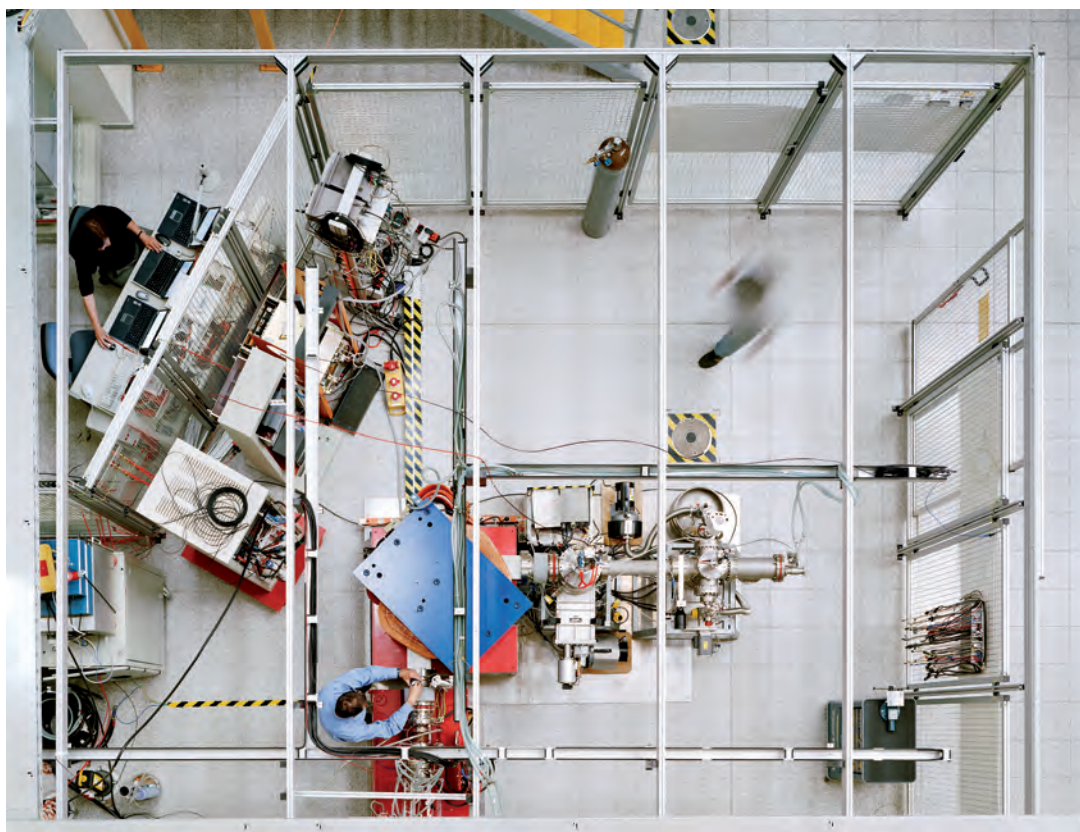

Figure 1:
Ion accumulation experiment (top view). The ions are generated in the ion source (bottom), deflected 90° towards the right by means of the separator magnet (in blue) and collected up to a weighable mass (photo: Marc Steinmetz/VISUM).

was abandoned after a reproducibility of 10^{-6} had been reached [12]. The Russian All Russia D I Medeleyev Scientific and Research Institute for Metrology (VNIIM) and the Finnish Centre for Metrology and Accreditation (MIKES) are planning to set up a new Magnetic Levitation Experiment [13]. PTB's ion accumulation experiment was launched in 1990. In this experiment (see Figure 1), $^{209}\text{Bi}^+$ ions (previously $^{196}\text{Au}^+$ ions) are accumulated to obtain a weighable mass; the ion current is integrated over the accumulation time and the current is measured via the quantum standards "Josephson voltage" and "quantum Hall resistance". In this way it was possible to determine the mass of a bismuth atom with a relative uncertainty of $9 \cdot 10^{-5}$. Although the principle of ion accumulation could be demonstrated [14], and although – conceptually – it can be regarded as a suitable experiment for a redefinition of the kilogram as the mass of a certain number of atoms, it hardly seems probable that it will achieve the required uncertainty within the envisaged time.

2.1 The Avogadro experiment

For the determination of the Avogadro constant, a sphere is made from a silicon single crystal which has a mass of approximately 1 kg (see Figure 2). Its mass m and its volume V are then determined and furthermore, the volume v_0 of the unit cell of the crystal is determined via the lattice constant and the molar mass M_{Si} of silicon (see also the article "Density: From the measure-

ment of a silicon sphere to Archimedes' principle" in this volume). With the known number of atoms in the unit cell n_{Si} , the Avogadro constant results as follows:

$$N_{\text{A}} = \frac{V(M_{\text{Si}}/m)}{(v_0/n_{\text{Si}})} = \frac{M_{\text{Si}}}{m_{\text{Si}}} \quad (1)$$

In other words, the Avogadro constant is the relation between the molar mass and the mean mass of a silicon atom m_{Si} . Natural silicon consists of the three isotopes ^{28}Si , ^{29}Si and ^{30}Si . Thus, for the determination of M_{Si} or m_{Si} , the relative isotope abundances of these three Si isotopes have to be measured. The volume of the sphere is obtained by measuring the sphere diameter and the roundness of the sphere by means of a spherical interferometer. The lattice constant is measured by means of an X-ray scanning interferometer. The mass of the sphere is obtained by comparison with a mass standard by means of a weighing instrument. Besides the measurements mentioned above, the chemical purity of the silicon, the thickness and the density of the oxide layer, and the quality of the crystal structure must be determined. The latest results published have been determined with silicon of natural isotopic composition in cooperation with different national metrology institutes (PTB, NMIJ, INRIM, NIST and IRMM) [9]. In 2003, an International Avogadro Coordination (IAC) was founded by a number of national metrology institutes as well as by the BIPM, the Russian International Science and Technology Center (ISTC)

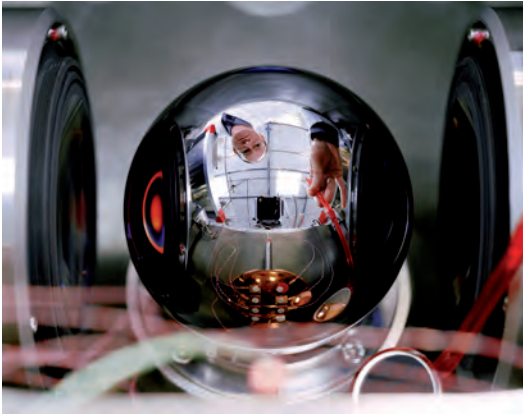

Figure 2:
Sphere made of a silicon single crystal for the determination of the Avogadro constant – here in PTB's sphere interferometer (photo: Marc Steinmetz/VISUM).

and the Berlin Institute for Crystal Growth (IKZ); it is working on a new way of determining the Avogadro constant with highly enriched ^{28}Si . Its ambitious goal is to achieve a value with a relative uncertainty of not more than $2 \cdot 10^{-8}$ by the end of 2009. The production of highly enriched silicon alone, with the aid of centrifuges at the ISTC, costs approx. 1.2 million euros.

2.2 The watt balance experiments

Planck's constant is determined by means of two tests (static mode and in-motion mode) with the aid of the watt balance (Figure 3). In the first test, the weight force of a mass standard is compared with an electromagnetic force by means of the balance (static mode). Thereby, the current is measured in a coil which is situated in the homogeneous field of a magnet. In the second test, the coil is moved vertically inside the same magnetic field (in-motion mode). Thereby, the speed and the voltage induced in the coil are measured. The equations for the current and for the induced voltage are then combined by eliminating the gradient of magnetic induction. One thus obtains the following:

$$UI = 4 mgv \quad (2)$$

where U is the induced voltage, I is the current in the coil, m is the mass of the mass standard, g is the gravitational acceleration, and v is the speed. Equation (2) applies to measurements in vacuum. In this equation, an electrical power is equated with a mechanical power, therefore the name "watt balance". If I and U are measured via the quantum Hall resistance and the Josephson voltage, one obtains Planck's constant:

$$h = \frac{4mgv}{V_m V_g} \quad (3)$$

where ν_m and ν_g are the frequencies of the microwave radiations which are measured in the case of the Josephson voltages during the first or the second test.

The watt balances at the different institutes [8] do not differ in their principle but in their practical realization. At the NPL and the NIST, masses of 1 kg are used, whereas METAS uses a mass of 100 g. The NIST uses a superconducting magnet and a cable pulley as a balance beam. The NPL and METAS use cobalt-samarium magnets; the NPL uses an equal-arm beam balance, METAS a modified commercial mass comparator. For the speed measurements, the NPL and the NIST use Michelson interferometers, whereas at METAS, a Fabry-Pérot interferometer is used. The BIPM is developing a watt balance with which both the static and the in-motion modes can be realized in one experiment. The LNE is developing and constructing a watt balance on its own which is suitable for a mass standard of 500 g and will operate with a cobalt-samarium magnet. For the measurement of the gravitational acceleration, nearly all the institutes use absolute gravimeters; the LNE is developing a gravimeter according to the fountain principle, with cold atoms.

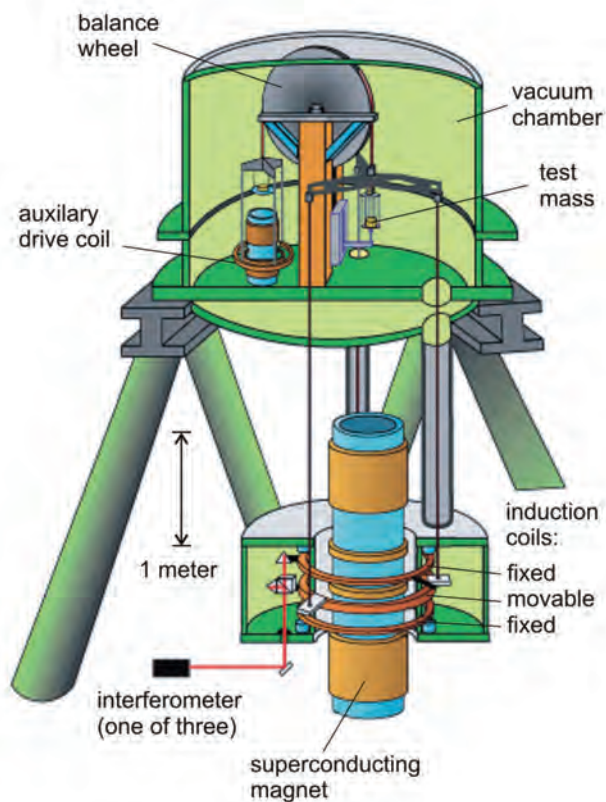

Figure 3:
Scheme of NIST's watt balance

3 Results achieved

The results of the measurements, along with the values of CODATA collected since 1980 for the Avogadro constant and other constants which were converted into values of the Avogadro constants, are shown in Figure 4. Thereby, the following conversions were used:

$$N_A = \frac{cA_r(e)M_u\alpha^2}{2R_\infty} \frac{1}{h} \quad (4)$$

$$N_A = \frac{cA_r(e)M_u\alpha^2}{2R_\infty} \frac{K_J}{2e} \quad (5)$$

$$N_A = \frac{F}{e} \quad (6)$$

where c = the speed of light, $A_r(e)$ = the relative atomic mass of the electron, $M_u = 10^{-3}$ kg mol⁻¹, α = hyperfine structure constant, R_∞ = Rydberg constant, K_J = the Josephson constant, F = the Faraday constant and e = the elementary charge. For the conversion, the CODATA values for 2006 were used [15]. The uncertainties stated here and below are simple standard uncertainties ($k = 1$).

The relative measurement uncertainties have decreased over the years from $1.3 \cdot 10^{-6}$ to $3.6 \cdot 10^{-8}$ for h and from $1.2 \cdot 10^{-6}$ to $3 \cdot 10^{-7}$ for N_A , but there remained a difference of approx. 10^{-6} between most of the results for h and N_A which is not compatible with the uncertainties, whereby the results for K_J from 1989 and 1991, and for F from 1980 are compatible with those for h (“not compatible” means that the difference is larger than the squared combined uncertainties). NPL’s latest value for h (2007) lies approx. $3 \cdot 10^{-7}$ from NIST’s latest value (2006) and is thus neither

compatible with the NIST’s value nor with the N_A value from 2005. Recent measurements at IRMM in 2009 have shown that the 2005 result for N_A has to be corrected with the effect that the 10^{-6} difference between h and N_A reduces by about one order of magnitude. It remains to be seen which results the current work of the IAC with enriched ²⁸Si will bring about for N_A .

4 Discussions in the bodies

Motivated by the publications of some members of the Comité Consultatif des Unités (CCU) [16,17], several consultative committees (CCs), international standardization bodies and the Comité International des Poids et Mesures (CIPM) have been dealing with the topic of a redefinition of the kilogram, as well as of further base units such as the ampere, the kelvin and the mole. All the bodies agree on the matter that redefinitions shall be formulated on the basis of fundamental constants such as h , N_A , e and k (Boltzmann constant). Thereby it is envisaged that the numerical values of such constants (according to CODATA) are laid down in the definitions so that in future, they will no longer be affected by any uncertainties – such as the speed of light according to the 1983 definition of the metre. Although the authors of [16] made proposals for decisions with regard to redefinitions already at the 2007 meeting of the Conférence Générale des Poids et Mesures (CGPM – the highest decision-making body of the Metre Convention), the CIPM has envisaged – due to the still existing discrepancies between the measurement results – the year 2011 as the earliest date.

For the kilogram, the Comité Consultatif pour la Masse et les Grandeurs Apparentées (CCM) has decided upon a recommendation

Figure 4:

Measurement results for the Avogadro constant N_A with uncertainties, represented as relative deviations from the CODATA 2006 value ($N_A = 6.02214179(30) \cdot 10^{23}$ mol⁻¹). The results for Planck’s constant, h , (watt balance), for K_J (voltage balance) and for the Faraday constant F have been converted by means of the CODATA 2006 constants. Explanation: “NPL-07-h”, for example, means: NPL’s result in 2007 for a measurement of h . “WGAC” means: Working Group “Avogadro Constant”.

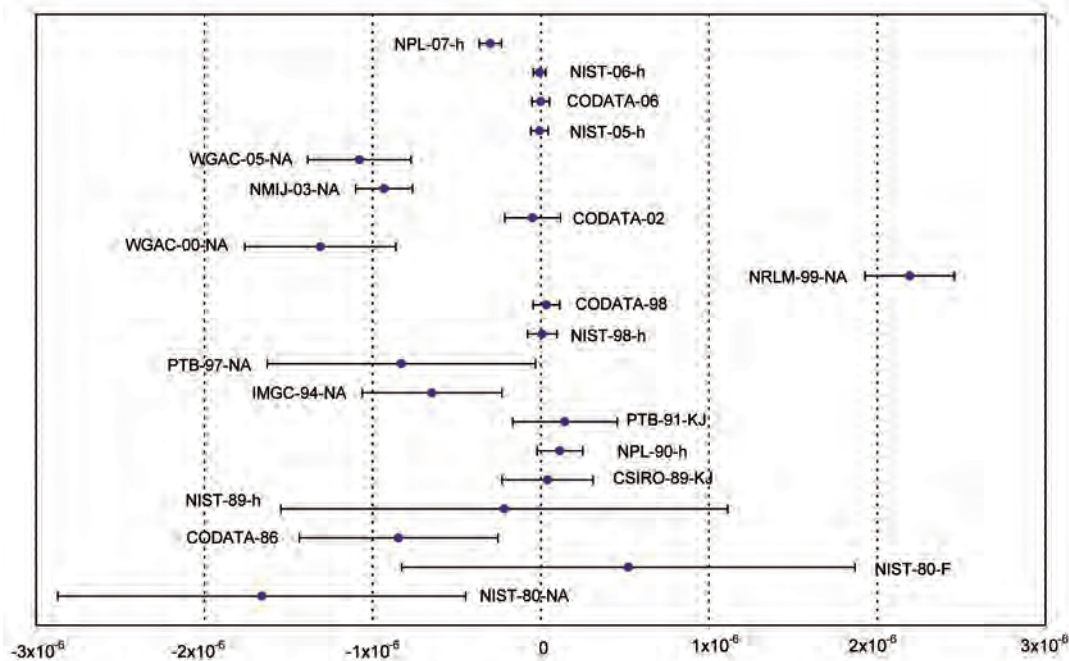

which, amongst others and according to the current requirements on weights in legal metrology, sets an upper limit of $2 \cdot 10^{-8}$ for the relative uncertainty for the realization of the unit “kilogram”.

Some other publications [18–23], consultative committees and standardization bodies have been dealing with the issue of the constants and the formulation of new definitions. The Comité Consultatif d'Electricité et Magnétisme (CCEM) has expressed its wish in a resolution that h and e shall be specified so that in future, the volt and the ohm will become SI units via $h/(2e)$ and h/e^2 , respectively. However, since only one electrical unit can be defined as a base unit, it is suggested to define the ampere via e and the kilogram via h . The suggestion to define the kilogram via h has, however, not been met with approval in all bodies. One group of authors, who are closely connected with the Avogadro Experiment, favours a kilogram definition which refers to an atomic mass [20], since such a definition would be easier to understand and would also make more sense from a physical point of view. In its latest recommendation (2007) to the CIPM, the CCU presented the viewpoints of the different bodies, but – as its own recommendation – has pointed out that it favours h as reference for the new definition of the kilogram. A decision with regard to this issue and with regard to a deadline for the redefinitions will probably not be taken until several experiments show a sufficiently good agreement and exhibit uncertainties that are accepted by the relevant bodies.

5 Summary

The currently relevant experiments – whose results can be a pre-condition for a redefinition of the kilogram – are the experiment for the determination of the Avogadro constant using a silicon single crystal, and the so-called “watt balance” for the determination of Planck’s constant via a mass standard. So far, the results still show incompatible differences and do not yet yield the uncertainties called for by the experts represented at the CCM. At the moment, redefinitions for the kilogram, the ampere, the kelvin and the mole are planned for 2011, provided the measurement results of the International Avogadro Coordination IAC, as well as of the NIST, the NPL and METAS, which are expected by 2009, permit this.

6 Literature

- [1] R.D. Deslattes, A. Henins: Phys. Rev. Lett. **31** (1973), 972–975
- [2] B.P. Kibble: A measurement of the gyromagnetic ratio of the proton by the strom field method, in: J. H. Sanders, A. H. Wapstra: Atomic Masses and Fundamental Constants vol. 5, Plenum, New York 1976, 545–551
- [3] B.P. Kibble, R.C. Smith, I.A. Robinson: The NPL Moving-Coil Ampere Determination, IEEE Trans. Instrum. Meas. **IM-32** (1983), 141–143
- [4] P.T. Olsen, M.E. Cage, W.D. Phillips, E.R. Williams: The Realization of the Ampere at NBS, IEEE Trans. Instrum. Meas. **IM-29** (1980), 234–237
- [5] P.T. Olsen, V.E. Bower, W.D. Phillips, E.R. Williams, G.R. Jones, Jr.: The NBS Absolute Ampere Experiment, IEEE Trans. Instrum. Meas. **IM-34** (1985), 175–181
- [6] R.L. Steiner, E.R. Williams, R. Liu, D.B. Newell: Uncertainty Improvements of the NIST Electronic Kilogram, IEEE Trans. Instrum. Meas. **56** (2007), 592–596
- [7] I.A. Robinson, B.P. Kibble: An initial measurement of Planck’s constant using the NPL Mark II watt balance, Metrologia **44** (2007), 427–440
- [8] A. Eichenberger, B. Jeckelmann, P. Richard: Tracing Planck’s constant to the kilogram by electromechanical methods, Metrologia **40** (2003), 356–365
- [9] K. Fujii, A. Waseda, N. Kuramoto, S. Mizushima, P. Becker, H. Bettin, A. Nicolaus, U. Kuetgens, S. Valkiers, P. Taylor, P. De Bièvre, G. Mana, E. Massa, R. Matyi, E.G. Kessler, Jr., M. Hanke: Present State of the Avogadro Constant – Determination From Silicon Crystals With Natural Isotopic Compositions, IEEE Trans. Instrum. Meas. **54** (2005), 854–859
- [10] W.K. Clothier, G.J. Sloggett, H. Bairnsfather, M.F. Curry, D.J. Benjamin: A Determination of the Volt, Metrologia **26** (1989), 9–46
- [11] T. Funk, V. Sienknecht: Determination of the Volt with the Improved PTB Voltage Balance, IEEE Trans. Instrum. Meas. **40** (1991), 158–161
- [12] F. Shiota, Y. Miki, Y. Fujii, T. Morokuma, Y. Nezu: Evaluation of equilibrium trajectory of superconducting magnetic levitation system for the future kg unit of mass, IEEE Trans. Instrum. Meas. **49** (2000), 1117–1121
- [13] K. Riski, P. Heikkinen, H. Kajastie, J. Manninen, H. Rossi, K. Nummala, E. Frantsuz, V. Khavinson: Design of a superconducting magnetic levitation system, Proc. 17th Int. Conf. IMEKO TC 3, Istanbul, 17–21- September 2001, 239–246
- [14] M. Gläser: Tracing the atomic mass unit to the kilogram by ion accumulation, Metrologia **40**, 376–386
- [15] P.J. Mohr, B.N. Taylor, D.B. Newell: CODATA Recommended Values of the Fundamental Physical Constants 2006, arXiv:0801.0028v1 [physics.atom-ph] 29 Dec 2007, 105 S.
- [16] I.M. Mills, P.J. Mohr, T.J. Quinn, B. N. Taylor, E.R. Williams: Redefinition of the kilogram: a decision whose time has come, Metrologia **42** (2005), 71–80
- [17] I.M. Mills, P.J. Mohr, T.J. Quinn, B. N. Taylor, E.R. Williams: Redefinition of the kilogram, ampere, kelvin and mole: a proposed approach to implementing CIPM recommendation 1 (CI-2005), Metrologia **43** (2006), 227–246
- [18] M. Stock, T.J. Witt: CPEM 2006 round table discussion, Proposed changes to the SI, Metrologia **43** (2006), 583–587
- [19] S.G. Karshenboim: On the redefinition of the kilogram and ampere in terms of fundamental physical constants, Physics Uspekhi **49** (2006), 947–954
- [20] P. Becker, P. De Bièvre, K. Fujii, M. Gläser, B. Inglis, H. Luebbig, G. Mana: Considerations on future redefinitions of the kilogram, the mole and of other units, Metrologia **44** (2007), 1–14
- [21] B.W. Petley: The atomic units, the kilogram and the other proposed changes to the SI, Metrologia **44** (2007), 69–72
- [22] M.T.J. Milton, J.M. Williams, S.J. Bennett: Modernizing the SI: towards an improved, accessible and enduring system, Metrologia **44** (2007), 356–364
- [23] J.W.G. Wignall: Some comments to the definition of mass, Metrologia **44** (2007), L19–L22

Realization of the Mass Scale

Michael Borys¹, Frank Scholz², Martin Firlus³

1 Introduction

The definition of the unit of mass is based on a material embodiment, the international prototype of the kilogram [1]. Thus, the definition and the realization of the SI base unit kilogram are identical. At the highest level of the hierarchy of mass standards, the dissemination of the unit of mass takes place by using copies of the international prototype of the kilogram made of the same material (90 % platinum, 10 % iridium), with the same dimensions and the same surface properties. These official copies are called „kilogram prototypes“ and are adjusted within a mass range of $1 \text{ kg} \pm 1 \text{ mg}$ [2].

In order to determine the masses of any solids, the realization and dissemination of sub-multiples and multiples of the mass unit kilogram are required. Based on a reference standard such as, for example, a kilogram prototype, a mass scale is derived with the aid of suitably divided weight sets according to a weighing scheme and using a least squares adjustment. As a result of this derivation, secondary standards traced back to the reference standard are available which realize the sub-multiples and multiples of the unit of mass and thus form the basis for the dissemination of the unit of mass in the derived mass range.

2 Hierarchy of the mass standards

Since the definition and realization of the unit of mass are linked to a material embodiment – i. e. to a kilogram prototype – the unit of mass is disseminated via an uninterrupted chain of mass comparisons. This results in a hierarchy of mass standards (Fig. 1). At the top of this hierarchical chain is the international prototype of the kilogram, which is maintained at the Bureau International des Poids et Mesures (BIPM). As a consequence of the sanctioning of the international prototype of the kilogram by the first General Conference on Weights and Measures in 1889, 30 out of 42 kilogram prototypes were distributed to the member states of the Metre Convention and the BIPM [3, 4]. At present, the Metre Convention has 51 member states and the number of kilogram prototypes has increased to more than

80. All copies of the international prototype of the kilogram bear a number. The Federal Republic of Germany's national kilogram prototype is the one with the number 52 and was purchased in 1954 (Fig. 2).

The dissemination of the unit of mass from the international prototype of the kilogram to the national kilogram prototypes generally takes place via the BIPM's working standards. The national kilogram prototypes are linked up with the BIPM's working standards approximately every 10 years. A comparison of the national kilogram prototypes with the international prototype of the kilogram is made at larger intervals within the scope of so-called periodic verifications. After the link-up of the first 42 kilogram prototypes between 1883 and 1888, the national kilogram prototypes have hitherto been called in for three periodic verifications: from 1899 to 1911 (at that time, they were not compared with the international prototype of the kilogram but to the kilogram prototype No. 1), from 1939/46 to 1953 (interruption due to WWII) and finally from 1989 to 1992 [3]. Depending on how long ago the last periodic verification took place, the mass of the national kilogram prototypes is determined at the BIPM with expanded measurement uncertainties ($k = 2$) in the range from $5 \mu\text{g}$ to $15 \mu\text{g}$ (relative $5 \cdot 10^{-9}$ to $1.5 \cdot 10^{-8}$).

At the national metrology institutes, the unit of mass is disseminated from the kilogram prototypes to the secondary standards. The secondary standards are nowadays mostly made of non-corrosive, non-magnetic steel (with a density of approx. 8000 kg/m^3). This link-up of the 1 kg primary standards to the national kilogram prototype places particular requirements on the determination of the air density due to the necessary transition from the density of $21\,500 \text{ kg/m}^3$ (Pt-Ir) to 8000 kg/m^3 (steel), since for a determination of the density of air on the basis of the air density parameters (temperature, pressure, humidity and CO_2 content), the uncertainty of the air buoyancy correction is considerably higher than the uncertainty contributions of the weighing process and of other influence quantities [5]. The link-up of secondary standards to the national kilogram

¹ Dr. Michael Borys,
Head of the Working
Group "Realization of
Mass",
e-mail:
michael.borys@ptb.de

² Dipl. Phys. Frank
Scholz, Working Group
"Realization of Mass",
e-mail:
frank.scholz@ptb.de

³ Martin Firlus, Working
Group "Realization of
Mass",
e-mail:
martin.firlus@ptb.de

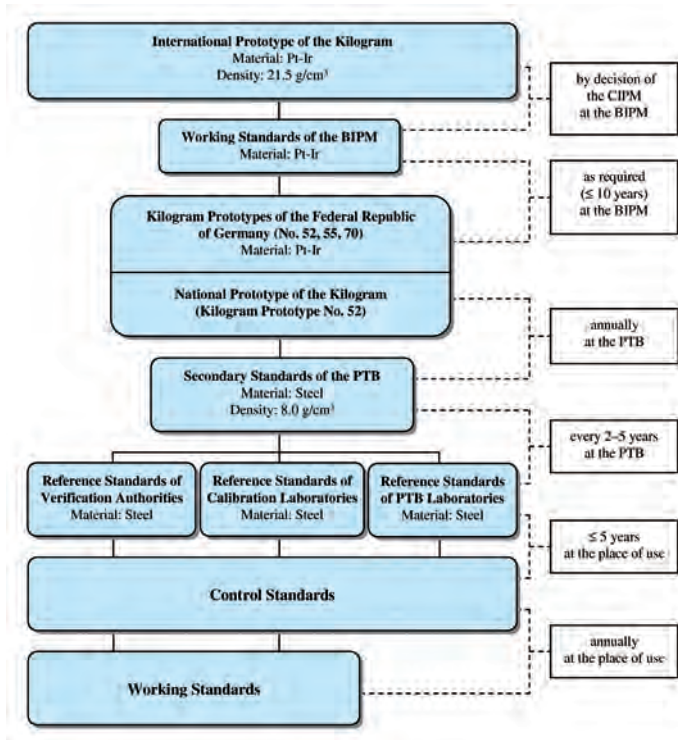

Figure 1:

Hierarchy of mass standards in the Federal Republic of Germany (Pt-Ir: alloy made of 90 % platinum and 10 % iridium; CIPM: Comité International des Poids et Mesures; BIPM: Bureau International des Poids et Mesures)



Figure 2:

The Federal Republic of Germany's kilogram prototype No. 52 (kept under two bell jars)

prototype is carried out on special 1 kg comparators, so-called "prototype balances" (Fig. 3). Prototype balances are nearly always accommodated in pressure-tight enclosures which can, for the most part, also be evacuated. Under stable pressure conditions and at temperature fluctuations of a few millikelvin, relative standard deviations of $\leq 3 \cdot 10^{-10}$ can be achieved with the aid of modern prototype balances. By weighing special air buoyancy artefacts in vacuum and air, air density determinations with relative uncertainties ($k = 1$) of approx. $2 \cdot 10^{-5}$ are possible [6, 7]. The transition from the national kilogram prototype to the secondary standards is the basis of the realization of sub-multiples and multiples of the mass unit kilogram in the form of a mass scale (section 4, Fig. 4). The mass scale generally comprises the range of nominal values which is needed on a regular basis and with particularly high requirements for the dissemination of the unit of mass. At PTB, this is, for example, the range from 1 mg to 5 t which can be realized with the smallest relative uncertainties U/m of up to $2.8 \cdot 10^{-8}$ ($k = 2$).

The reference standards of institutes, authorities of legal metrology and other institutions in research, industry and metrology are linked up with PTB's secondary standards (Fig. 1). In further steps, subordinate reference, control and working standards are then calibrated with the aid of these reference standards. Within PTB, the base unit kilogram is disseminated to derived units (e.g. density, pressure, force).

The highest requirements are placed on the mass stability of prototypes, secondary standards, reference standards and control standards. Each usage can influence the mass stability and may cause damage. The intervals for recalibrations must therefore be chosen in such a way that mass changes are detected as soon as possible. In Fig. 1, estimated values for the intervals between two link-ups are indicated for each step of the hierarchy. It must thereby be taken into account that for fixing the recalibration intervals, the individual stability of a standard, as well as the frequency and the conditions of its use are decisive.

3 Realization of a mass scale

3.1 Weighing scheme

In general, high-precision mass determinations are carried out by means of differential weighings of the same nominal value. When calibrating whole sets of weights, however, the problem may occur that only one reference standard with a certain nominal value is available.

In that case, a determination of the set of weights in itself is necessary, with a link-up to the reference standard. The same procedure is used for the derivation of sub-multiples and multiples of the unit of mass from the national kilogram prototype. For this purpose, mass comparisons are carried out with certain combinations of mass standards with the aid of a suitable weighing scheme. In legal metrology, the subdi-

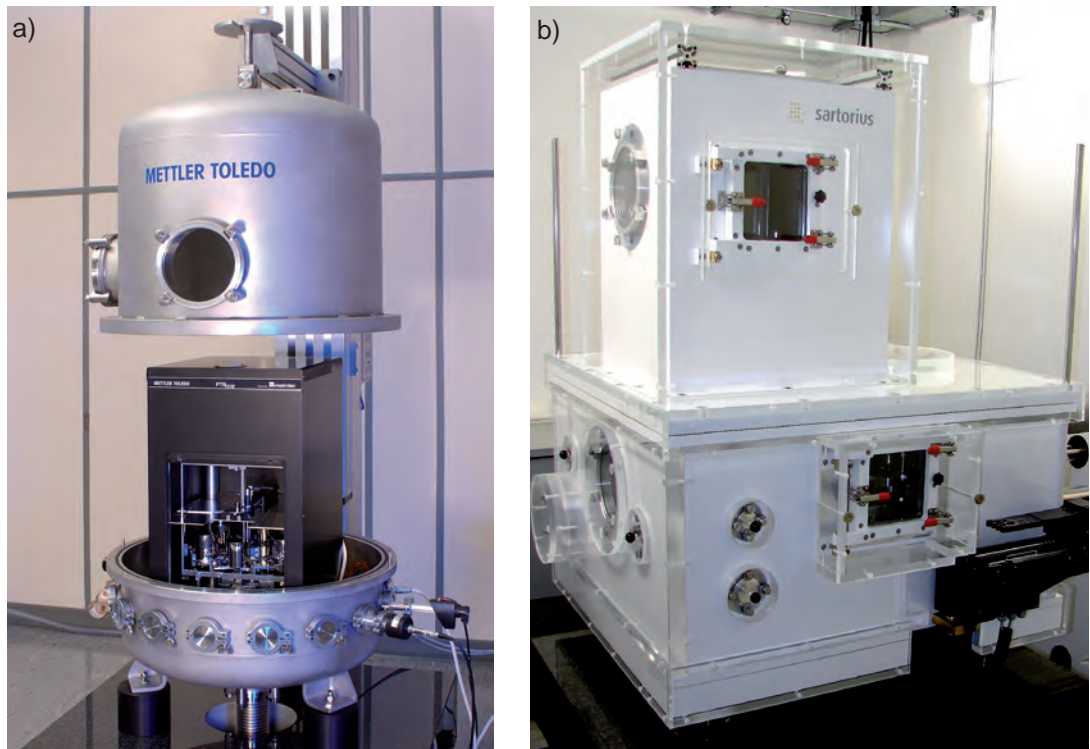

Figure 3a-b:

PTB's prototype balances (1 kg vacuum mass comparators, installed in vacuum-resistant chambers).

a) Mettler-Toledo M_one: automatic weight exchange facility with 6 positions, resolution 0.1 μg , standard deviation $\leq 0.3 \mu\text{g}$;

b) Sartorius CCL1007: automatic weight exchange facility with 8 positions, resolution 0.1 μg , standard deviation $\leq 0.2 \mu\text{g}$

vision of the standards by the factors $1 \cdot 10^n$, $2 \cdot 10^n$ and $5 \cdot 10^n$, $n \in \{\dots, -2, -1, 0, 1, 2, \dots\}$ is laid down internationally [8].

The system of weighing equations used can be represented with the aid of a weighing scheme and allows the establishment of a mass scale for each decade. Besides the reference standard, seven further standards per decade are used at PTB so that each nominal value exists twice. For the first link-up weighing with a known mass $m_{1\text{kg}}$ the following equation applies:

$$m_{1\text{kg}} - m'_{1\text{kg}} = x(1), \quad (1)$$

where

$m_{1\text{kg}}$ mass of the standard with the nominal value 1 kg (No. 1);

$m'_{1\text{kg}}$ mass of the standard with the nominal value 1 kg (No. 2);

$x(1)$ mass difference as a result of the first weighing.

By further determinations, such as, e. g.,

$$m_{1\text{kg}} - (m_{500\text{g}} + m'_{500\text{g}}) = x(2), \quad (2)$$

$$m_{500\text{g}} - m'_{500\text{g}} = x(4), \quad (3)$$

it is possible to carry out just as many mass comparisons as standards of unknown mass are

available, or even more. In this way, each decade and thus each set of mass standards can be derived from a standard of known mass.

Depending on the requirements and on the given subdivision of a set of weights, different weighing schemes can be applied. Figure 4 shows an example of a weighing scheme with seven unknown standards divided into 1, 1, 2, 2, 5, 5, 10 and ten weighing operations in each decade as is standard at PTB. The first line illustrates that, during the first weighing, the known 1 kg standard (symbol "+") is compared with the unknown 1 kg standard (symbol "-"). The weighing result of this comparison is $x(1)$. From the equation system with 10 equations and 7 unknowns, it is possible to calculate the sought masses of the individual standards. Since this is an over-determined equation system, the sought masses can be determined by means of a least squares adjustment. In addition, the least squares adjustment provides the covariance matrix, a square, symmetrical matrix whose diagonal elements contain the variances of the mass standards involved. Since all unknown standards are derived from a known standard, their masses are correlated. The corresponding variances contain the non-diagonal elements of the variance-covariance matrix. If combinations of these standards are used in the course

of subsequent calibrations, the covariances must be taken into account for the calculation of the uncertainty.

In the next decade, the now known 100 g standard will be compared with the unknown standards according to the weighing scheme described in the first decade. All following decades, e. g. down to 1 mg, as well as the decades for nominal values higher than 1 kg will be derived successively in the same manner.

The utilisation of such a weighing scheme with more weighing equations than the number of weights to be calibrated allows the control of potential weighing errors by the comparison of the weighing results observed with the weighing results calculated via the least squares adjustment.

3.2 Mass comparators

Since comparison measurements are always carried out with standards of the same nominal values according to the substitution method, it is not the absolute value of the balance's indication which enters into the measurement result, but only the weighing difference. For such differential weighings, mass comparators are used. Compared to their maximum capacity, they only have a relatively small weighing range which can, however, be resolved highly and with very small linearity deviations. The (electric) weighing range, for instance, of the prototype balance shown in Fig. 3a with a maximum capacity of 1 kg is only 1.5 g. This range, however, has a resolution of 0.1 µg, i. e. $1.5 \cdot 10^7$ steps, and a maximum linearity deviation of $\pm 2 \mu\text{g}$. In practice, one tries to minimize the influence of linearity deviations as far as possible by limiting the weighing differences by means of appropriate mass standards (auxiliary weights) to max. 10 % of the weighing range. In order to rule out the influence of linear drifts (e. g. caused by temperature variations), repeated comparisons of the test object (T) with the reference standard (R) are carried out at equal time intervals, whereby each weighing cycle consists of several (most of the time 3 to 6) successive weighing operations in the order R-T-T-R. Four successive balance readings m_{B_i} each yield an averaged, drift-corrected weighing difference:

$$\Delta m_B = \frac{-m_{B1} + m_{B2} + m_{B3} - m_{B4}}{2} \quad (4)$$

For the dissemination of the unit of mass over several decades, several mass comparators and balances must be used at PTB. A characteristic value for mass comparators and balances is the standard deviation, which should not exceed a certain limit for repeated weighing cycles, depending on the required uncertainty. Table 1 shows a selection of the balances and mass com-

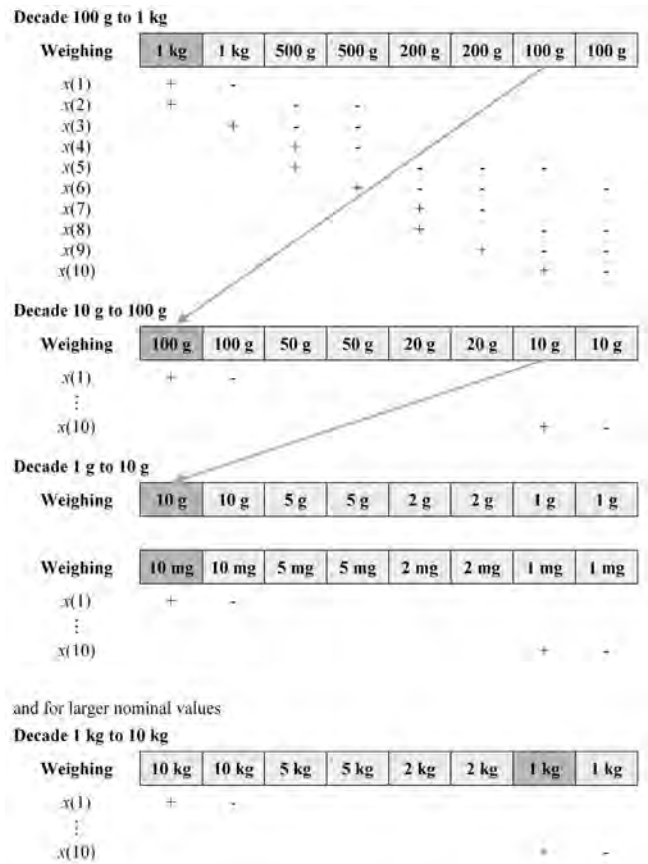

Figure 4: Example of the derivation of a mass scale according to a weighing scheme with 7 unknown standards and 10 weighing operations per decade

parators (with their essential characteristics) as they are used at PTB for the realization of the mass scale and mass determinations with highest accuracy.

3.3 Mass standards

The linguistic usage often distinguishes between mass standards and weights acceptable for (official) verification – whereby “acceptable for verification” is generally omitted. A mass standard is characterized by its mass and the uncertainty of the mass. Its properties must be such that sufficient mass stability – in relation to the uncertainty – is ensured within the recalibration intervals. For weights acceptable for verification, international directives and recommendations as well as national prescriptions apply which lay down the maximum permissible errors, the materials, the shape, the magnetic properties, the surface quality, etc. [8, 11–13]. Mass standards should at least fulfil the requirements which are placed on weights of comparable uncertainty with regard to the surface quality and the magnetic properties.

In PTB's mass scale, secondary standards with nominal values in the range of 1 mg to 50 kg are in use. With a total of a hundred 50 kg standards, PTB's mass scale is realized up to 5 t.

Table 1:

Data of the balances and mass comparators used at PTB for the realization of the mass scale and for high-precision mass determinations (selection), (*Max*: maximum capacity, *d*: scale interval, *s*: standard deviation, s_{rel} : relative standard deviation in relation to the usable maximum capacity)

Range of nominal values	<i>Max</i> / <i>d</i>	Weighing principle	<i>s</i>	s_{rel}
1 mg ... 5 g	5 g / 0.1 µg	Electronic comparator balance with full electromagnetic force compensation	0.3 µg	$6 \cdot 10^{-8}$
10 g ... 100 g	111 g / 1 µg	Mass comparator with automatic weight exchange facility, 4 positions	1.2 µg	$1.2 \cdot 10^{-8}$
100 g ... 1 kg	1 kg / 0.1 µg	Vacuum mass comparators with automatic weight exchange facility, 6 or 8 positions (prototype balances)	0.3 µg	$3 \cdot 10^{-10}$
2 kg ... 10 kg	10 kg / 10 µg	Mass comparator with automatic weight exchange facility, 4 positions	20 µg	$2 \cdot 10^{-9}$
20 kg ... 50 kg	64 kg / 0.1 mg	Mass comparator with automatic weight exchange facility, 4 positions	0.4 mg	$8 \cdot 10^{-9}$
100 kg ... 200 kg	200 kg / 20 mg	Mechanical, equal-armed beam balance	0.2 g	$1 \cdot 10^{-6}$
500 kg ... 5000 kg	5000 kg / 60 mg	Mechanical, equal-armed beam balance with automated acquisition of measured data	0.6 g	$1.2 \cdot 10^{-7}$

Figure 5 gives an overview of the uncertainties of PTB's secondary standards. The indicated uncertainties correspond to the smallest uncertainties with which mass standards can be calibrated at PTB in accordance with PTB's entries in the BIPM's CMC tables [14]. The uncertainties given in the BIPM's CMC tables have been confirmed within the scope of international comparison measurements (key comparisons) and are, in accordance with Annex C of the Mutual Recognition Arrangement (MRA) of the International Committee for Weights and Measures (CIPM) [15], mutually recognised by all participating institutes.

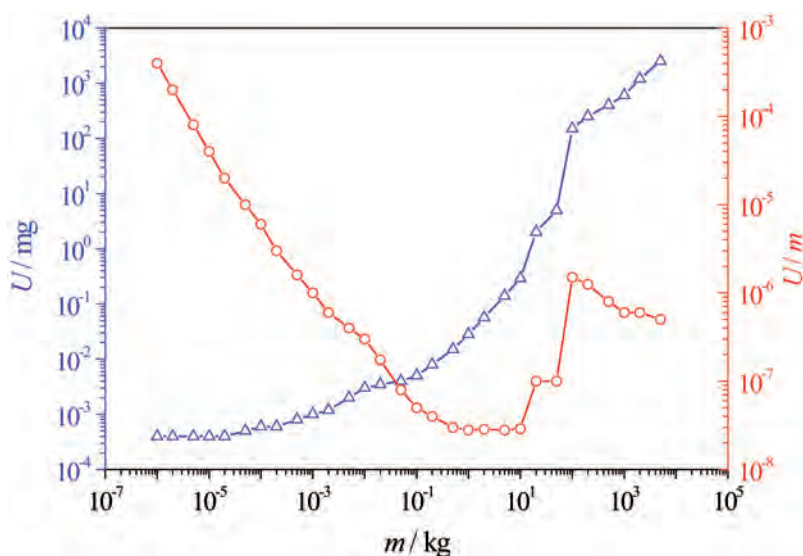

Figure 5:

Expanded uncertainties ($k = 2$) of PTB's secondary standards for the realization of the mass scale (triangles: absolute values U in mg; circles: relative values U/m)

4 Summary

Sub-multiples and multiples of the mass unit kilogram are derived from the national kilogram prototype as the so-called „mass scale“. The derivation is carried out according to a weighing scheme with the aid of weight sets having an appropriate subdivision. The weighing scheme is generally set up in such a way that an overdetermined system of weighing equations is yielded. The masses of the standards involved as well as their variances and covariances are calculated by using a least squares adjustment. The mass scale is derived for the nominal values which are needed on a regular basis and with particularly high requirements. At PTB, this is the range from 1 mg to 5 t, which is realized with relative uncertainties ($k = 2$) of $2.8 \cdot 10^{-8}$ (for 1 kg) to $4 \cdot 10^{-4}$ (for 1 mg). PTB's secondary standards form the basis for the dissemination of the unit of mass to the reference standards of institutions and authorities of legal metrology, calibration laboratories in industrial metrology and other institutions in research, industry and metrology.

Literature

- [1] Bureau international des poids et mesures (BIPM): Le Système international d'unités (SI) – The International System of Units (SI). 8th edition, Paris/Sèvres 2006
- [2] Kochsiek, M.; Schwartz, R.: The Unit of Mass. In: Kochsiek, M.; Gläser M. (eds.): Comprehensive Mass Metrology. Wiley-VCH, Weinheim 2000
- [3] Girard, G.: The third periodic verification of national prototypes of the kilogram (1988–1992). *Metrologia* 31 (1994), pp. 317–336

- [4] *Gläser, M.*: 100 Jahre Kilogrammprototyp. PTB-Bericht **MA-15**, Physikalisch-Technische Bundesanstalt, Braunschweig 1989
- [5] *Schwartz, R.; Borys, M.; Scholz, F.*: Guide to mass determination with high accuracy. PTB-Bericht **MA-80e**, Wirtschaftsverlag NW, Verlag für neue Wissenschaft, Bremerhaven 2007
- [6] *Chung, J. W.; Borys, M.; Firlus, M.; Lee, W. G.; Schwartz, R.*: Bilateral comparison of buoyancy artefacts between PTB and KRISS. *Measurement* **40** (2007), pp. 761–765
- [7] *Madec, T.; Meury, P. A.; Sutour, C.; Rabault, T.; Zerbib, S.; Gosset, A.*: Determination of the density of air: a comparison of the CIPM thermodynamic formula and the gravimetric method. *Metrologia* **44** (2007), pp. 441–447
- [8] International Recommendation OIML R 111: Weights of classes $E_1, E_2, F_1, F_2, M_1, M_{1,2}, M_2, M_{2,3}$ and M_3 , Part 1: Metrological and technical requirements. OIML, Paris 2004
- [9] *Bich, W.*: From the SI mass unit to multiples and submultiples: an overview. *Metrologia* **40** (2003), pp. 306–311
- [10] *Bich, W.*: Variances, covariances and restraints in mass metrology. *Metrologia* **27** (1990), pp. 111–116
- [11] EEC Directive 74/148: Weights from 1 mg to 50 kg of above-medium accuracy. Official Journal of the European Community L 84/3 of 28/3/1974
- [12] EEC Directive 71/317: 5 kg to 50 kg medium accuracy rectangular bar weights and 1 g to 10 kg medium accuracy cylindrical weights. Official Journal of the European Community L 202/14 of 6/9/1971
- [13] Eichordnung (Verification Ordinance) Annex 8 (EO 8), Gewichtstücke, Part 1: EWG-Anforderungen, Part 2: Innerstaatliche Anforderungen, Braunschweig 2004
- [14] <http://kcdb.bipm.org/appendixC/>
- [15] <http://www.bipm.org/en/cipm-mra/>

Density: From the Measuring of a Silicon Sphere to Archimedes' Principle

Horst Bettin¹, Michael Borys², R. Arnold Nicolaus³

1 Density

The (mass) density ρ of a solid is defined as the quotient of its mass m and its volume V : $\rho = m/V$. The unit of density is therefore kg/m³. Whereas the shape of a test piece is of rather subordinate importance for mass determinations by weighing, volume determination by means of geometrical measurements works only with simple and nearly perfectly shaped solids (Figure 1). The volume of a cube, for example, can be calculated on the basis of its edge length a : $V = a^3$. For the most accurate volume determinations, spheres have proved their worth whose diameter d is measured by means of interferometric methods: $V = \pi/6 \cdot d^3$.

The density of liquids and gases is defined analogous to the density of solids, whereby the density is generally determined indirectly in comparison to solid density standards.

Density is of great economic importance everywhere where the price of a product is related to the volume, but where the mass is measured (or vice versa). In the case of flowing liquids and gases, mass, for example, is determined on the basis of a volume measurement with the aid of simultaneous density measurements. Whereas for these purposes, a relative uncertainty of $1 \cdot 10^{-3}$ to $1 \cdot 10^{-4}$ is sufficient, in oceanography, in which the ocean currents caused by density differences are studied, relative uncertainties lower than $1 \cdot 10^{-5}$ are required (all uncertainties are standard uncertainties, i. e. for $k = 1$). Within the scope of the present discussions on climate change, such measurements are particularly interesting. Especially for model calculations, the exact knowledge of the water density as a function of temperature and pressure is necessary. Tables and formulas for the density of water allow the use of ultra-pure water as a density standard. Such water is easy to prepare and ensures, even without taking into consideration dissolved air or the exact isotopic composition, a low relative uncertainty of $1 \cdot 10^{-5}$. Similarly, pure mercury is used as a density standard to

trace back the pressure measurement to the height measurement of a mercury column (the pressure p of a liquid column is $p = g \rho_1 h$, where g is the gravitational acceleration of the Earth, ρ_1 the density of the liquid and h the height of the liquid column).

The density of silicon is currently of considerable importance for the field of metrology because – thanks to the high perfection of single-crystal silicon – it can be expected that it will be possible to determine the Avogadro constant with a relative uncertainty clearly lower than $1 \cdot 10^{-7}$. It would thus be possible to define the mass unit kilogram as a multiple of an atomic mass (see article “Redefinition of the Kilogram” in this volume). In the International Avogadro Project, the number of silicon atoms in a 1 kg silicon sphere is determined by measuring the volume of the sphere and the spacing between the atoms inside the crystal [1]. For this purpose, it is necessary to measure the volume with a relative uncertainty of $1 \cdot 10^{-8}$; researchers worldwide are presently working on achieving this goal. As a spin-off, the most accurate density standards consist of silicon single crystals today.



Figure 1:
Examples of primary density standards: 1 kg silicon sphere and Zerodur cube

¹ Dr. Horst Bettin, Head of the Working Group “Density of Solids”, e-mail: horst.bettin@ptb.de

² Dr. Michael Borys, Head of the Working Group “Realization of Mass”, e-mail: michael.borys@ptb.de

³ Dr. R. Arnold Nicolaus, Head of the Working Group “Interferometry on Spheres”, e-mail: arnold.nicolaus@ptb.de

2 Mass determination of density standards

The mass of density standards is traced back to the base unit kilogram [2]. At the national metrology institutes, the primary density standards are either connected directly to the national kilogram prototypes or to the primary standards of the mass scale derived from these. The mass determination is carried out as a differential weighing according to the substitution method, in which the mass standard (A) and the density standard (B) are compared successively on the same weighing pan of a high-resolution mass comparator. In order to suppress the influence of linear drifts, the comparisons are carried out in the form of repeated weighing cycles, whereby each cycle is composed of several consecutive weighing operations in the order A-B-B-A. For a mass comparison in air with the density ρ_a between a mass standard of the mass m_A and the volume V_A and a density standard of the mass m_B and the volume V_B , as well as for a weighing difference $\Delta m'_{W,B-A}$ (already corrected for air buoyancy), it is possible to establish the following weighing equation [3]:

$$m_B = m_A + \rho_a \cdot (V_B - V_A) + \Delta m'_{W,B-A} \quad (1)$$

The uncertainty with which the mass of a density standard can be determined thus depends on the uncertainty components of the mass of the reference weight, of the air density, of the volume difference between the reference weight and the density standard as well as of the weighing process.

The silicon spheres used as primary density standards for highest requirements at national metrology institutes (mass: 1 kg, density: 2329 kg/m³) all exhibit, when compared with the kilogram prototypes of platinum-iridium (density 21 500 kg/m³), a volume difference of approx. 380 cm³ and thus a buoyancy difference $\rho_a (V_B - V_A)$ of nearly half a gram. The large volume difference leads to the fact that the uncertainty contribution of the air density is the most significant in the uncertainty budget of the mass determination; therefore, it is indispensable that the highest requirements be placed on the determination of the density of the air.

In general, the air density is determined on the basis of the following parameters: pressure, temperature, humidity and CO₂ content. The calculation of the air density is carried out according to the air density formula recommended by the Comité International des Poids et Mesures (CIPM), which is also known as the "CIPM equation" [4]. If the measurement of the air density parameters is carried out with the greatest effort, it is possible to achieve a relative uncertainty of

the air density determination $u(\rho_a)/\rho_a$ of approx. $6 \cdot 10^{-5}$ when using the CIPM equation. In this case, the air density determination alone causes an uncertainty contribution of approx. 30 μ g (relative $3 \cdot 10^{-8}$) for the link-up of a 1 kg silicon sphere to the prototype.

An even smaller measurement uncertainty can be achieved by weighing two buoyancy artefacts. The buoyancy artefacts are designed in such a way that they have practically equal masses (m_1, m_2) and surfaces, but exhibit a volume difference ($V_1 - V_2$) as large as possible. The difference of the masses ($m_1 - m_2$) is determined by a weighing under vacuum, i. e. without correction for air buoyancy, and the volume difference is determined by hydrostatic weighing (see section 5). When these differences are known, the density of the air can be calculated on the basis of the weighing difference of the buoyancy artefacts in air, ($m_{W1} - m_{W2}$), by means of the equation [3]:

$$\rho_a = \frac{(m_1 - m_2) - (m_{W1} - m_{W2})}{V_1 - V_2} \quad (2)$$

With this method, it is possible to achieve relative uncertainties $u(\rho_a)/\rho_a \leq 3 \cdot 10^{-5}$ for the determination of the air density and $u(m)/m \leq 2 \cdot 10^{-8}$ for the determination of the mass of 1 kg silicon spheres [5, 6] (Figure 2).

In view of the great influence of the buoyancy correction, it is advantageous to determine the mass of silicon spheres under vacuum conditions. Thereby it must, however, be taken into account that the reference mass and the density standard (silicon sphere) underlie mass alterations when subjected to an air-vacuum transfer which are caused by reversible and irreversible sorption effects. The adsorption and desorption of water and hydrocarbons at the surface of the two standards depend on the material, the roughness, the state of surface cleanliness and the humidity of the air. These effects can be estimated by weighing two sorption artefacts (same material and same surface properties, equal mass, surface areas as different as possible) in air and

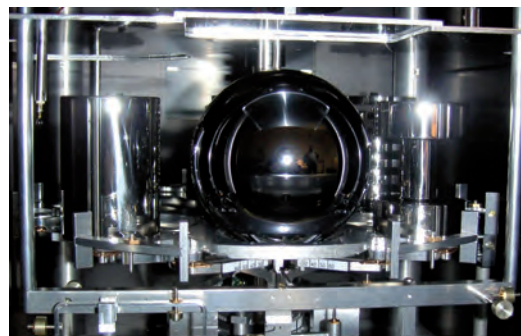

Figure 2:

Mass determination of a 1 kg silicon sphere by using air buoyancy artefacts for the determination of the air density (left: hollow cylinder, right: bobbin).

under vacuum. This has allowed the mass of silicon spheres under vacuum (i.e. without the contribution of physically sorbed water layers in the air) to be determined already with relative uncertainties $u(m)/m \leq 1 \cdot 10^{-8}$ [6].

3 Determination of the volume of silicon spheres

For the dimensional measurement of material measures, interferometric methods had already been used at the beginning of the 20th century, as the non-contact measuring procedure shows obvious advantages – compared to mechanical sampling, whose uncertainty contributions are difficult to estimate. In general, one distinguishes between two-beam (Michelson, Twyman-Green) and multiple-beam (Fizeau, Fabry-Pérot) interferometers – depending on the number of waves contributing to the interference. Interferometers working according to the Fizeau principle have the advantage of being able to carry out also absolute determinations of the form errors by exchanging the optical surfaces and by measuring in various positions. Interferometry has, thanks to the procedures of phase-shift interferometry [7], gained considerably in importance since the total visual field can now be analysed with high local resolution due to the improved signal resolution, on the one hand, and electronic camera systems, on the other. For rectangular objects, interferometry has proven to be very suitable. Besides the actual measuring of the linear dimensions, also deviations in the topography of the object faces are made visible. As material measures for density measurements, however, spheres are used preferably, as the risk of edge damages is thus minimized and as both shape and volume stability are hence ensured.

For the measurement of the volume, it is now necessary to measure the diameter of the sphere. The first non-contact diameter measurement goes back to the “ball interferometer” according to J. B. Saunders [8]. Two wedge plates are assembled by means of precise spacers to form a Fabry-Pérot etalon. With the sphere in the etalon, Newton rings are formed in the laser light between the surface of the sphere and the adjacent Fabry-Pérot plate. The basic idea comprises two measurements: firstly, the plate distance D of the etalon is determined. Then, the sphere is placed between the plates and the two air gaps d_1 and d_2 between the sphere and the respective etalon plate are determined. The sphere diameter d then results from $d = D - d_1 - d_2$.

Considerations on significantly improving the knowledge of shape deviations of the sphere and its influence on the determination of the volume have finally led to a new concept of a sphere interferometer [9]. Thereby, the interferometric concept is fully adapted to the measuring object: since it is a sphere, the etalon is made of two concentric spherical surfaces and an – also concentrically adjusted – spherical wave (Figure 3) is used. Thus, the interfering waves, both in the empty etalon and with the sphere inside, are always spherical waves and thus allow the interference to be analysed in the total field of view. With an aperture ratio of the sphere objectives of 1:1, this corresponds to a cone with an angle of 60°. For the analysis of the interference, electronic cameras are used and the phase is calculated with algorithms commonly used in the analysis of two-dimensional interferences. For full coverage, the sphere must be re-oriented several times and is then characterized by approx. 200 000 diameters. Figure 4 shows a typical diameter topography.

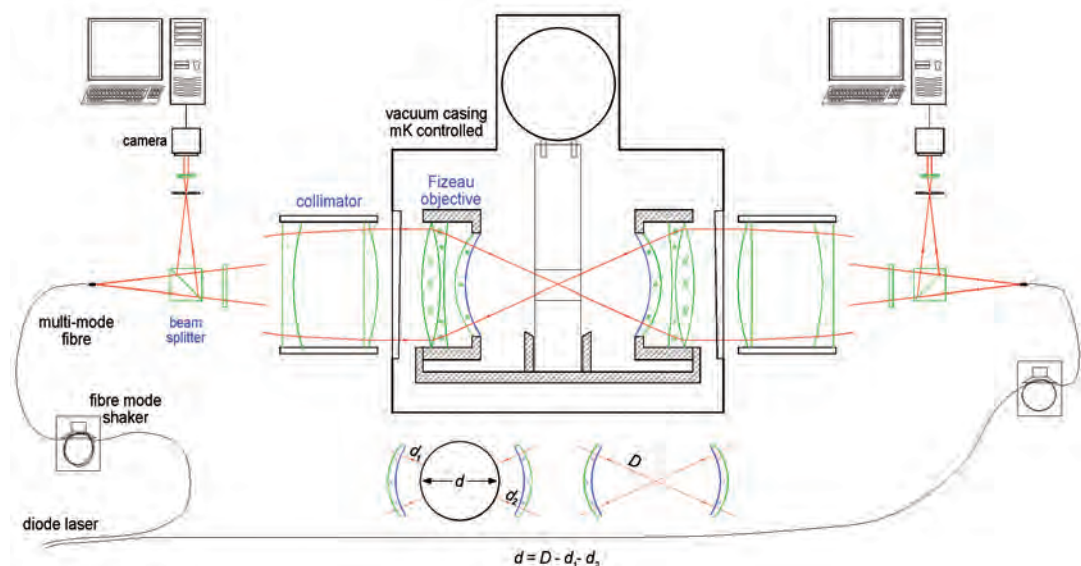

Figure 3:
Sphere interferometer [9]

For the absolute diameter of a sphere, a series of corrections are necessary. Despite the low thermal expansion coefficient of silicon, a temperature variation of 4 mK corresponds to an alteration in diameter of 1 nm. In each interferometric measurement, the temperature of the sphere is determined by means of a special thermocouple measurement system. Thermocouples have the advantage of not influencing the temperature sensor and the measured object by heating measurement currents and can resolve sub-mK temperature differences to a copper block that serves as a temperature reference point. Platinum resistance thermometers and AC resistance ratio bridges are used to determine the absolute temperature of this reference point.

In order to reduce the influence of the refractive index of air, precision measurements are carried out in vacuum. Here, however, the use of phase-shift interferometry is restricted to step-wise changes of the wavelength. This requires special frequency-measuring and stabilisation techniques for the lasers used.

The aperture correction results from the size of the light source (here the exit surface of an optical fibre) since the light rays which start at a point outside the optical axis travel a longer distance. This correction is given by the dimensions of the light source and is therefore the same for all measurements.

The influences of the parameters mentioned lead to a relative measurement uncertainty of currently $3 \cdot 10^{-8}$ for the interferometrically measured volume.

Silicon oxidises very fast under ambient conditions, the surface of the silicon sphere is therefore covered by a layer of different silicon oxides. Due to the refractive indexes of the silicon core and of the surface layers, the incident light is affected by a phase shift on reflection so that the thickness of the surface layer is underestimated by the optical measurement. For the calculation of this optical phase shift, a layer model is used for which, on the basic material silicon, a thin transition layer of SiO and a layer of SiO₂ are assumed. Based on layer thickness determinations, and with the optical properties of the materials, a correction for the optical measurement can be calculated. For example, the layer thickness generated in usual polishing processes is approx. 3 nm, whereas the apparent thickness of such a layer system reaches only 10% of this value at a wavelength of 633 nm. The measurement uncertainty of the layer thickness is smallest at higher thicknesses of 5 nm to 10 nm, so that for future measurements, the silicon spheres will be thermally oxidised. High numbers of layer thickness measurements can be obtained by ellipsometric measurements so that a silicon sphere can be characterized satisfacto-

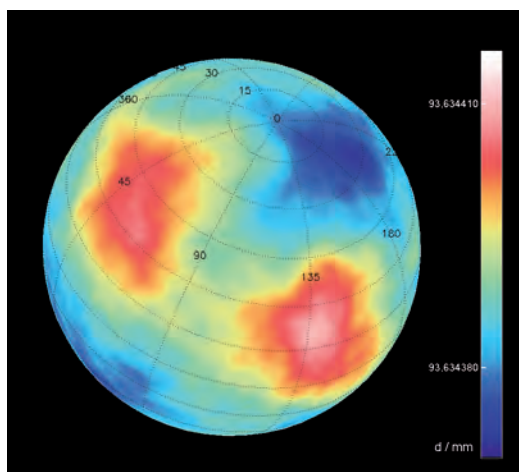

Figure 4:
Diameter topography of a precision silicon sphere

rily over its total surface. Ellipsometry, however, only provides relative layer thickness values and must therefore be combined with absolute layer thickness measurements, for example, by X-ray reflectometry measurements (XRR).

The measurement uncertainty for the total volume is, at present, approx. $3 \cdot 10^{-8}$. For the Avogadro Project, however, the aim is to achieve a reduction down to $1 \cdot 10^{-8}$ (for special purposes, with a special sphere).

4 Maintenance of the density unit

The most accurate density determination by means of mass and length measurements, i. e. the primary link-up to the units of mass and length or the realization of the density unit – is currently achieved with a relative standard uncertainty of approx. $4 \cdot 10^{-8}$. This low uncertainty requires a detailed definition as to which part of the surface one attributes exactly to the density standard, in particular to the silicon sphere. It is sensible to use a definition which rules out the hydrocarbon and water layers on the surface, since these layers are variable or reversible. The hydrocarbons can be nearly fully removed by cleaning the surface thoroughly, and the water film on silicon depends on the air humidity. Thus, only the irreversible water proportion which is contained in the oxide layer of the silicon and – even in vacuum – does not evaporate should be attributed to the density standard. This definition requires corrections for all measurements in which variable or reversible surface layers play a role.

There are two different methods to check the primary link-up of a density standard. First, the density of one and the same sphere can be determined via the mass and diameter in different devices. Such a comparison was carried out in 1996 with four silicon spheres [10] and is currently being repeated with a new sphere. Second, it is possible to compare the sphere with other – primarily linked-up – density standards by means of density-measuring methods. This has

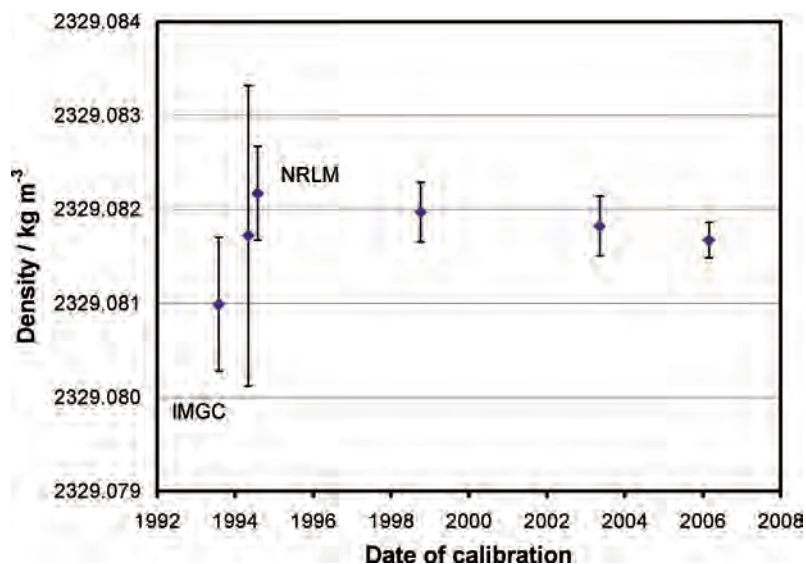

Figure 5: Calibrations of the sphere Si1PTB at PTB, together with the results of the Italian and Japanese national metrology institutes IMGC (today: INRIM) and NRLM (today: NMIJ) [11].

been carried out within the scope of several key comparisons and bilateral comparisons. These international comparisons meanwhile ensure the consistency of all primary density standards with less than $1 \cdot 10^{-6}$.

The greatest problem for the maintenance of the density unit is the proof of long-term stability of the density standards between the calibrations (which are performed relatively rarely). Silicon single crystals offer the best pre-conditions for this purpose since structural changes – as they may occur in glass-like solids – can be ruled out due to the solid crystalline structure. Besides, the oxide layer of quartz glass protects the silicon from environmental influences and from most chemicals. Alkaline solutions, however, may corrode silicon and thus lead to a reduction in mass. Furthermore, in the case of improper use, material can be mechanically removed from the surface, e.g. due to scratches. Also during cleaning in the ultrasonic bath, material may be removed from the surface due to cavitation effects. Such alterations can be detected by high-resolution mass comparators [2] by means of comparison weighings before and after the treatment.

Furthermore, a slowly progressing oxidation of the sphere's surface must be expected because the oxide layer has a thickness of only a few nm. This hardly leads to an alteration of the sphere's density, since the oxide layer has roughly the same density as silicon (oxide: 2230 kg/m^3 , silicon: 2329 kg/m^3). By means of ellipsometric or X-ray-interferometric measurements, it would be possible to detect a growth of the oxide layer. Except for during the first days after the etching away of an oxide layer, no further change in the thickness has so far been observed.

Finally, there is also the possibility that substances may find their way into the interior of the crystal: copper atoms, for example, can diffuse into a silicon crystal even at room temperature. The solubility of copper in silicon is, however, so small that a measurable alteration of the mass is impossible. The same is true for hydrogen, which can diffuse into or – if the crystal is supersaturated with hydrogen – out of the crystal.

The most accurate investigations of the long-term stability of density standards have been carried out by means of floatation measurements (see section 5). PTB's silicon density standards have been compared with each other several times within 12 years. Although the spheres had been subjected to different usages and procedures, their density changed (relative to each other) by less than $1 \cdot 10^{-8}$ per year. Absolute density measurements over more than 12 years are also available (see Figure 5) [11]. Since formerly, the uncertainties used to be rather large, however, it can only be estimated that the density changes are smaller than $2 \cdot 10^{-8}$ per year. The situation with the mass determinations of density standards is similar: it is only within the past few years that the uncertainty could be reduced so far that good estimates of the drift can be made when the measurements are repeated in a few years. Thereby, it must also be taken into account that, strictly speaking, only the difference to the (unknown) drift of the international prototype of the kilogram can be determined. Mass comparisons of approx. 40 national kilogram prototypes and the official copies (the so-called "témoins") with the international prototype have shown a significant drift of approx. $50 \mu\text{g}$ in 100 years (i.e. relative $5 \cdot 10^{-10}$ per year) and suggest that the international prototype possibly exhibits a mass drift compared to a fundamental constant such as an atomic mass.

5 Dissemination of the density unit

Since the primary link-up is very laborious and only possible for almost perfectly shaped solids, comparison methods are used to determine the density of other solids, but also of liquids and gases [12] (Figure 6). Most methods use Archimedes' principle, according to which a solid in a liquid apparently loses as much weight as the displaced liquid weighs. The apparent weight of a solid (as compared to calibrated weights) is thus measured by means of the hydrostatic balance. Based on this result, one calculates – if the mass is known – the apparent weight loss or the buoyancy $\rho_1 V g$ and – if the volume V of the solid is known – the density ρ_1 of the liquid. Vice versa, if the density of the liquid is known, it is possible to determine the volume of a solid sample. In this way it is possible to determine, for example, the volume

of other, secondary density standards, of weights or of artefacts for the measurement of the air density. If the sample and the standard have a very similar mass and volume, the highest accuracy is achieved if the apparent weights of the sample and the standard are compared both in the liquid and in air and only the (small) differences are measured. In this way, the volumes (and densities) can be compared with a relative uncertainty below $5 \cdot 10^{-8}$ [13].

Hydrostatic weighing is also used for the calibration of hydrometers according to the so-called Cuckow method. Thereby, the hydrometer is weighed while it is immersed – up to the scale line to be checked – into a liquid of known density (and surface tension) [12]. Hydrometers are a cheap and reliable means to determine density or, indirectly (if the density dependence is known) the concentration of dissolved substances in liquids. In legal metrology, they are used to measure alcohol content. Nowadays, densimeters of the oscillation type are used more often to determine the density of liquids because they only need a very small amount of liquid, can be automated and can be integrated into industrial processes. In these devices, the frequency of a vibratory arrangement is measured which is filled with or surrounded by the liquid. These devices must, however, be calibrated at regular intervals with liquids of known density. Furthermore, the measurement is influenced by the viscosity of the liquid because the way the liquid vibrates depends not only on its density but also on its viscosity.

In floatation procedures, the special case of Archimedes' principle is used where the weight is fully compensated by the buoyancy in the liquid. The exact adjustment of the densities can be realized, for example, by means of a pressure change in the liquid ("pressure-of-floatation", Figure 7). From the difference of the pressures at which two samples are floating it is then possible to calculate, by means of the compressibility of the liquid, the density difference of the samples. Whereas in hydrostatic weighing, a wire is used to lead to the balance, no wire is used in this method, which permits a much higher accuracy to be achieved. In this way, silicon samples with relative uncertainties of $2 \cdot 10^{-8}$ can be compared. Also small samples can be measured with a very high accuracy, thanks to this method. This fact is exploited within the scope of the Avogadro Project to detect density differences in the silicon crystal and to seek crystal defects [14].

In the magnetic floatation method, a permanent magnet which hangs on the sample and on a float is used to keep the sample in a state of floatation. The density of water is presently being re-determined by means of this method [15]. But it

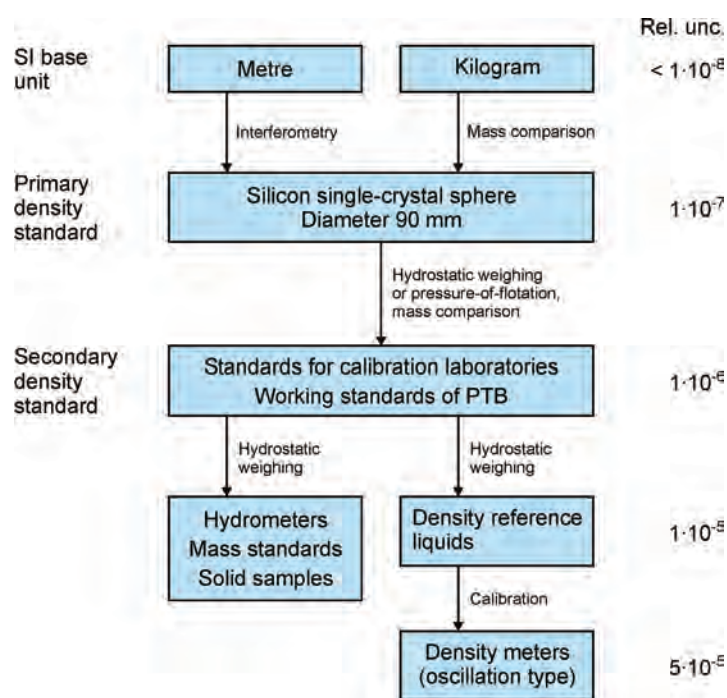

Figure 6:
Hierarchy for the realization and dissemination of the density unit.

can also be used for comparing the density of solids. The main advantage here, again, is that there is no wire leading to the balance and traversing the surface of the liquid.

For gases, another apparatus has proved to be appropriate which also allows a closed measuring vessel: the density standard in the measuring vessel is connected to a balance through the wall of the vessel by means of a magnetic coupling mechanism [16]. This magnetic suspension coupling is particularly well-suited to determine the equations of state of natural gases over a wide temperature and pressure range.

6 Outlook

In the past hundred years, the accuracy of the realization of the density unit has improved by a factor of nearly 100: at the beginning of the 20th century, an uncertainty of approx. $2 \cdot 10^{-6}$ was achieved when it was checked whether the mass of the kilogram prototype was in agreement with the former definition as the mass of 1 dm³ of water at 4 °C. Today, the most accurate primary density standards have an uncertainty of approx. $4 \cdot 10^{-8}$, whereby an improvement to $1 \cdot 10^{-8}$ is aspired to for the coming years within the scope of the Avogadro Project. But the development may advance even further: in the roadmap for the kilogram in the European Metrology Research Programme (EMRP), it is envisaged to reduce the uncertainty of the Avogadro constant to $1 \cdot 10^{-9}$ by 2020, which would, if using the method without alterations, imply a similar uncertainty for density.

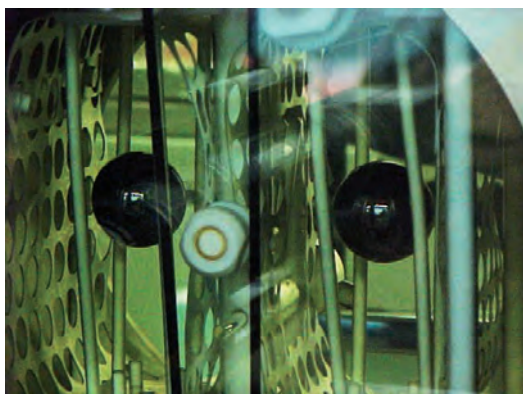

Figure 7:

Two 30 mm silicon spheres in the measuring vessel of the pressure-of-floatation equipment.

The methods of measurement with which the density unit is maintained and disseminated have been correspondingly improved. Especially floatation methods have the potential to achieve measurement uncertainties below $1 \cdot 10^{-8}$. This opens up new fields of application. Thus, by means of pressure-of-floatation, the density of an oxide layer of 0.1 μm thickness on a silicon sphere could be determined with an uncertainty of less than 1%. If, in addition, the mass and the surface of the layer are known, then the average thickness of the layer can be calculated.

All in all, density measurements will also in future be able to measure up to the permanently increasing requirements of economy and science.

Literature

- [1] *Becker, P. et al.*: Large-scale production of highly enriched ^{28}Si for the precise determination of the Avogadro constant. *Meas. Sci. Technol.* **17** (2006), 1854–1860
- [2] *Borys, M.; Scholz, F.; Firlus, M.*: Realization of the Mass Scale. *PTB-Mitteilungen* **118** (2008), 10–15
- [3] *Schwartz, R.; Borys, M.; Scholz, F.*: Guide to Mass Determination with High Accuracy. *PTB-Bericht PTB-MA-80e*, March 2007
- [4] *Picard, A.; Davis, R. S.; Gläser, M.; Fujii, K.*: Revised formula for the density of moist air (CIPM-2007). *Metrologia* **45** (2008), 149–155
- [5] *Borys, M.; Gläser, M.; Mecke, M.*: Mass determination of silicon spheres used for the Avogadro project. *Measurement* **40** (2007), 766–771
- [6] *Picard, A.*: Mass determinations of a 1 kg silicon sphere for the Avogadro project. *Metrologia* **43** (2006), 46–52
- [7] *Creath, K.*: Phase-measurement interferometry techniques. *Progress in optics XXVI*, *E. Wolf* (Ed.) (1988), 349–393
- [8] *Saunders, J. B. sr.*: Ball and Cylinder Interferometer. *Journal of Research of the NBS (J. Res. Nat. Bur. Stand.)* **76C** (1972), 11–12
- [9] *Nicolaus, R. A.; Bönsch, G.*: A Novel Interferometer for Dimensional Measurement of a Silicon Sphere. *IEEE Trans. Instrum. Meas.* **46** (1997), 563–565
- [10] *Bettin, H.; Gläser, M.; Spieweck, F.; Toth, H.; Sacconi, A.; Peuto, A.; Fujii, K.; Tanaka, M.; Nezu, Y.*: International Intercomparison of Silicon Density Standards. *IEEE Trans. Instrum. Meas.* **46** (1997), 556–559
- [11] *Bettin, H.; Toth, H.*: Solid density determination by the pressure-of-floatation method. *Meas. Sci. Technol.* **17** (2006), 2567–2573
- [12] *Spieweck, F.; Bettin, H.*: Review: Solid and liquid density determination. *tm – Technisches Messen*, **59** (1992) 237–244, 285–292
- [13] *Fujii, K.*: Precision density measurements of solid materials by hydrostatic weighing. *Meas. Sci. Technol.* **17** (2006), 2551–2559
- [14] *Becker, P.; Bettin, H.; Kuetgens, U.; Hallmann-Seiffert, B.; Riemann, H.*: Silicon for primary metrology: the effect of hydrogen on its perfection. *J. Phys. D: Appl. Phys.* **38** (2005), 4109–4114
- [15] *Wolf, H.; Bettin, H.; Gluschko, A.*: Water density measurement by a magnetic floatation apparatus. *Meas. Sci. Technol.* **17** (2006), 2581–2587
- [16] *Wagner, W.; Kleinrahm, R.*: Densimeters for very accurate density measurements of fluids over large ranges of temperature, pressure, and density. *Metrologia* **41** (2004), S24–S39

Mass Determinations and Weighing Technology in Legal Metrology

Roman Schwartz¹, Panagiotis Zervos², Oliver Mack³,
Karsten Schulz⁴

1 Introduction

National and international trade, commercial transactions and industrial processes are nowadays inconceivable without mass determinations and weighing technology. Weighing technology is thereby no longer restricted to simple weighings with individual instruments; today, intelligent, networked weighing systems control numerous manufacturing processes and procedures in trade and industry where weight – or “mass”, to be precise – is often required as the leading measurand. Examples of this are the counting of small workpieces on the basis of their mass, the determination of the length of pressed parts on the basis of their diameter and mass, and the dosing of bulk material mixtures and liquid products by means of continuous and discontinuous weighing.

Weighing instruments are classified into two categories: non-automatic and automatic weighing instruments. Whereas non-automatic weighing instruments require the intervention of an operator during the weighing operation, automatic weighing instruments follow a predefined sequence of characteristic automatic processes. It is not always easy to draw the exact line between non-automatic and automatic weighing instruments. Today, non-automatic weighing instruments have very short weighing cycles and quasi-automatic weighing functions so that the intervention of an operator is limited to the very minimum. In case of doubt, the internationally convened definition according to [1] applies. One thing, however, is common to all weighing instruments: they determine the mass on the basis of the force effect which the product to be weighed exerts onto its support in the Earth's field of gravity.

Within the last thirty years, weighing technology has evolved radically – following thereby the course of general technical progress; modern weighing instruments have almost nothing in common any more with the traditional, mechanical balances. Approximately since 1980, electronic weighing instruments, whose “core” is the so-called “load cell”, have almost completely replaced mechanical scales. Thanks to the rapidly progressing microprocessor technology,

the existing functions of a balance have been considerably extended and new functions could be realized which, due to significantly shorter measuring times and due to a clearly improved compensation of the disturbing values, have led to a huge increase in functional safety and operator convenience with, at the same time, a reduction in costs. For instance, the input and output of weighing data via digital interfaces have greatly extended the scope of application of weighing instruments. Almost at the same time, modular weighing systems have established themselves in particular in industrial applications in which various load receptors and peripheral devices can be operated with a single indicator. Of course, most modern weighing instruments have in the mean time become Internet-compatible.

Weighing instruments allow mass determinations within a very broad application range extending from 0.1 µg to nearly 1000 t, i.e. over practically 16 orders of magnitude. For certain applications, especially in the case of weighings for commercial and official purposes, verified weighing instruments with a type approval or a type examination certificate – e.g. issued by the Physikalisch-Technische Bundesanstalt (PTB) – must be used. Hereby, non-automatic and automatic weighing instruments must fulfil the requirements of European and international regulations, standards, recommendations and directives. This ensures that “weighing instruments in the area regulated by law” always work correctly and reliably within determined maximum permissible errors.

In the following, the most important load cell principles and types of non-automatic and automatic weighing instruments will be introduced as they are used in particular in legal metrology.

2 Load cells

The core piece of any electronic weighing instrument is, as already mentioned, the load cell. From a physical point of view, load cells do not differ from force transducers [2–4]. However, the areas of application, the technical requirements and, last but not least, also the applicable regulations sometimes differ significantly from each other so that in weighing technology, a term of

¹ Dr. Roman Schwartz, Head of the Division “Mechanics and Acoustics”, e-mail: roman.schwartz@ptb.de

² Dr. Panagiotis Zervos, Head of the Department “Mass” e-mail: panagiotis.zervos@ptb.de

³ Oliver Mack, Working Group “Weighing Instruments” e-mail: oliver.mack@ptb.de

⁴ Karsten Schulz, Head of the Working Group “Dynamic Weighing” e-mail: karsten.schulz@ptb.de

its own – “load cell” – has become widely accepted. In weighing instruments subject to legal control, mostly load cells tested and certified according to the international recommendation OIML R60 [5] or WELMEC Guide 2.4 [6] are used. These fulfil, depending on their accuracy class, certain requirements for sensitivity, linearity and reproducibility, for the creep and hysteresis behaviour, the zero point stability in a defined temperature range (mostly -10 °C to $+40\text{ °C}$), and for the humidity and ambient pressure behaviour. The performance characteristics for load cells are defined in both OIML R60 and Directive VDI/VDE 2637 [7]. The testing of load cells according to OIML R60 is not trivial; it requires, besides a loading machine with a sufficiently high nominal load and a sufficiently low relative measurement uncertainty (generally $\leq 1 \cdot 10^{-5}$), an appropriate temperature chamber which can be mounted into the loading machine. Figure 1 shows such a temperature chamber

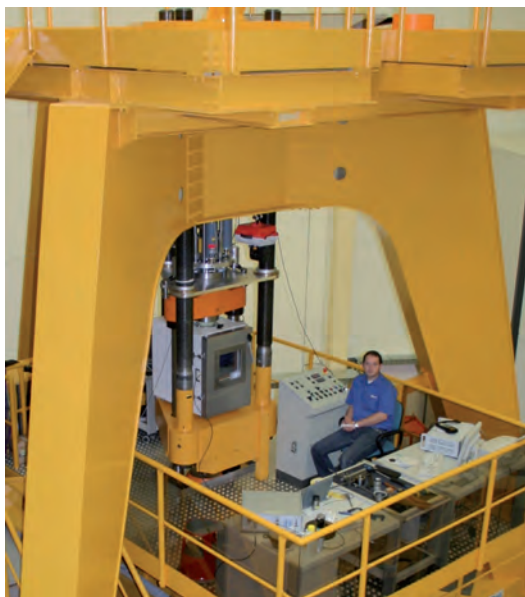

Figure 1: Temperature chamber mounted into PTB's 2-MN-K-NME (see centre of the picture, with viewing window) for the testing of load cells with a maximum capacity of up to 200 t according to OIML R60 (temperature range: -20 °C to $+55\text{ °C}$).

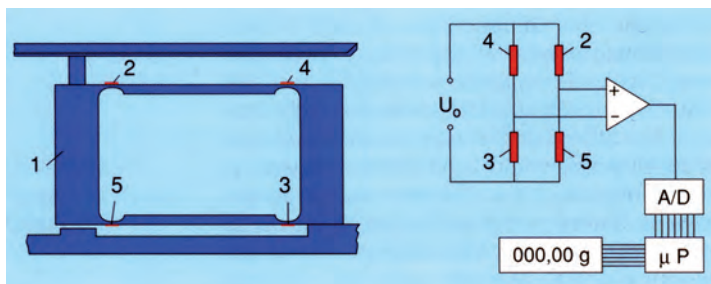

Figure 2: Fundamental set-up of a weighing instrument with a double bending beam as a strain gauge load cell and electronic evaluation unit [11] (*explanations in the text*).

which can be mounted into PTB's 2-MN force standard machine (K-NME) for the testing of load cells with a maximum capacity of up to 200 t [8].

Most of the weighing instruments used in trade and industry work with strain-gauge load cells. The strain gauges are applied onto a suitably shaped metallic body designated as a “mechanical spring”. The weight force causes an elastic deformation of the mechanical spring which is detected by the strain gauges and converted into an electrical resistance change. This, in turn, can easily be converted into an electric signal proportional to the weight force [2, 9–11]. More accurate weighing instruments with relative resolutions smaller than $\leq 1 \cdot 10^{-5}$, however, mainly use the principle of electromagnetic force compensation. In this case, the weight force causes a proportional change of a coil current [2, 11]. In the following, both principles will be described in more detail

proportionales, elektrisches Signal umgeformt werden [2, 9–11]. Genauere Waagen mit relativen Auflösungen kleiner $1 \cdot 10^{-5}$ nutzen dagegen meist das Prinzip der elektromagnetischen Kraftkompensation (EMK). Hier bewirkt die Gewichtskraft eine proportionale Änderung eines Spulenstroms [2, 11]. Im Folgenden werden beide Prinzipien näher erläutert.

2.1 Weighing instruments with strain gauge load cells

The fundamental set-up of a weighing instrument with a strain gauge load cell is depicted in Figure 2 [11].

The mechanical spring of the load cell consists of a parallel stay system and is called a “double bending beam”; it bends slightly under the force of the applied load. The counterforce to the applied load is exerted by the elastic deformation of the mechanical spring (1) which contains 4 thin plates (= flexible bearings) to which 4 strain gauges (2–5) are applied. Two strain gauges (2, 3) are compressed (resistance lowering) and two (4, 5) are stretched (resistance rising). The total, load-dependent resistance change is detected as a voltage signal in a Wheatstone bridge circuit and electronically processed. With digital measuring data processing, strain gauge weighing instruments can achieve resolutions of approx up to 10^5 scale intervals today. Depending on the design of the strain gauge load cell and the scope of application of the weighing instrument, numerous balance designs can be realized; further examples would, however, go beyond the scope of this article; reference to complementary bibliography is therefore provided [12–15].

Strain gauge load cells only require a very small mounting volume; lever systems are usu-

ally not required. This is of particular advantage for the construction of crane scales, mono-rail suspension weighers, large hopper weighers and road vehicle weighers. Strain gauge load cells display a long-term stability, even under conditions of high humidity, if they are hermetically enclosed in a metallic encapsulation or otherwise protected. Figure 3 shows typical, commercially available strain gauge load cells: Figure 3a) shows a double bending beam load cell with a metallic bellow for the hermetic encapsulation, whereas in Figure 3b, a shear beam load cell is shown whose strain gauges are protected from environmental influences by moulded metallic covers or welded caps [15].

Impurities are relatively uncritical – except for aggressive media or mechanical clampings of the weighing platform. The measuring range (range of application) of a strain gauge load cell used for the weighing range of a balance may, in general, be reduced to 30 % – in some cases even to 15 % – of the nominal load of the load cell, without having to reduce the given number of scale intervals n_{LC} . This allows a high protection against mechanical overload to be achieved. Strain gauge load cells are generally constructed in such a way that they can be loaded with at least 150 % of their nominal load E_{max} .

The focal point of the current developments in the field of strain gauge load cells is the improvement of their metrological properties along with a reduction of the production costs. The nominal loads of commercially available strain gauge load cells extend from approx. 5 kg to approx. 500 t; if one considers exceptions, this range even extends from 0.2 kg to over 1000 t. The state-of-the-art for standard applications is strain gauge load cells of class C with $n_{LC} = 3000$; if higher requirements are placed on the accuracy, strain gauge load cells of up to $n_{LC} = 6000$ are available. A few strain gauge load cells also fulfil the requirements for $n_{LC} = 7500$, whereby the load cells comply with the maximum permissible errors pursuant to OIML-R60 in the total temperature range from $-10\text{ }^{\circ}\text{C}$ to $+40\text{ }^{\circ}\text{C}$. In order to limit costs, strain gauge load cells made of alloyed aluminium or stainless steel with integrated guides (platform load cells or single point load cells) are mainly manufactured for scales for direct sales to the public which can absorb torsion torques without any measurement deviations worth mentioning, so that no further stays or guides are necessary within the weighing instrument [15].

2.2 Weighing instruments with electromagnetic force compensation load cells

In weighing instruments with electromagnetically force compensated load cells, changes in the weight force are converted into proportional

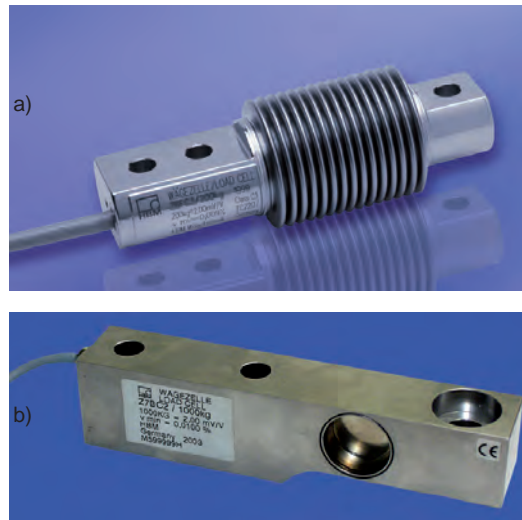

Figure 3:
Examples of typical, commercially available strain gauge load cells (the photos are the property of the manufacturer Hottinger Baldwin Messtechnik (HBM)).
a) Double bending beam load cell with a metallic bellow for the hermetic enclosure.
b) Shear beam load cell with moulded metallic covers or welded caps to protect the strain gauge from environmental influences.

current changes. The fundamental functioning of a weighing instrument with an electromagnetic compensation load cell is shown in Figure 4 [11].

The load receptor (1) is connected to the coil (6) fixed to the lever via a pair of stays (2, 3) which are supported by two solid spring joints (4, 5). The weight force exerted by the mass of the product to be weighed is compensated by the electromagnetic force of the current-carrying coil (6) which is located in the slit of a permanent magnet (7). With the aid of an optical position detector at the end of the lever, the coil current is regulated in a feedback circuit in such a way that the lever always takes the same position, independent of the loading. In the feedback circuit, a precision resistance (8) is integrated from which the load-proportional signal is taken, processed via an A/D converter (9) by a microprocessor (10), and finally displayed (11).

Modern laboratory scales with electromagnetic force compensation load cells nowadays achieve relative measurement uncertainties of approx. $1 \cdot 10^{-7}$ in the upper loading range of approx. 100 g to 10 kg when the mass of the product to be weighed is read out directly. So-called

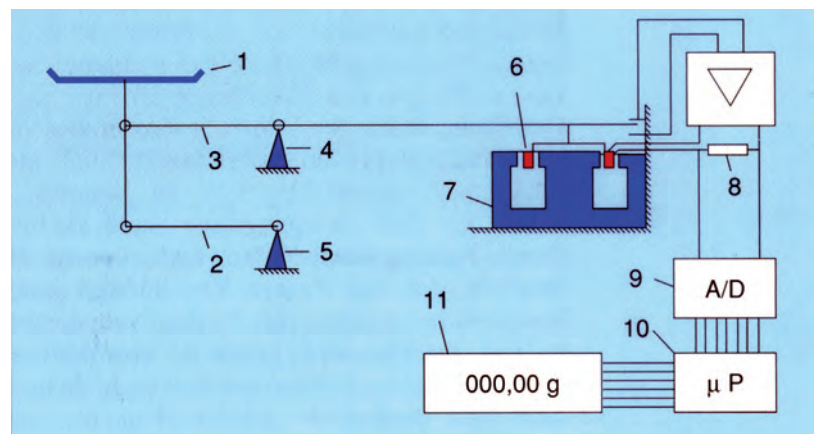

Figure 4:
Principle of a weighing instrument with an electromagnetic compensation load cell [11] (explanations in the text).

comparator balances (or mass comparators), with which substitution weighings – i. e. mass comparisons of a test piece against a reference standard – are carried out, even achieve relative measurement uncertainties of $1 \cdot 10^{-8}$ and less. For weighing instruments subject to legal control of the highest accuracy class (class I), so-called special accuracy weighing instruments, only electromagnetic force compensation load cells come into consideration. Also for high accuracy weighing instruments subject to legal control (class II), practically only electromagnetic force compensation load cells are used. There are many more than 100 different commercial electromagnetic force compensation load cell types [15] subject to legal control; the trend is going towards monolithic (i. e. manufactured out of one solid piece) electromagnetic force compensation load cells, as shown in Figure 5 with the example of a monolithic electromagnetic force compensation load cell with a bell-crank lever system.

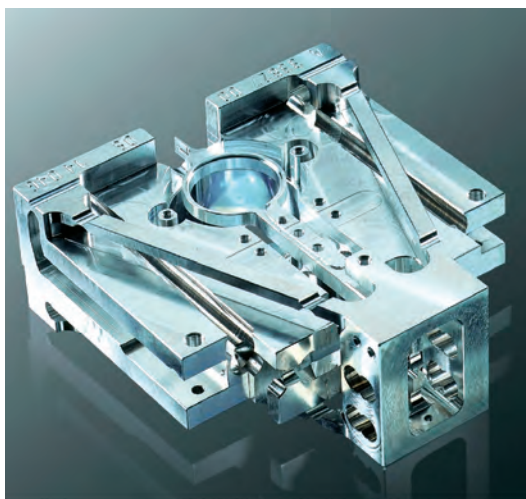

Figure 5:
View of a monolithic electromagnetic force compensation load cell with a bell-crank lever system
(the photograph is the property of Sartorius AG).

Electromagnetic force compensation load cells with extremely high resolutions can only be used sensibly under stable ambient conditions; for mass comparators, e. g., an air-conditioned measurement room with a temperature stability of at least ± 0.2 K is required and other influencing parameters besides temperature must also be considered such as air buoyancy, magnetic and electrostatic influences and convection [13, 16]. Special accuracy weighing instruments which are subject to legal control must comply with the metrological requirements in a temperature range of at least ± 2.5 K, whereas a minimum range of ± 7.5 K is prescribed for high accuracy weighing instruments [1, 17–19].

In order to achieve relative measurement uncertainties of $\leq 1 \cdot 10^{-5}$, special and high accuracy equipped with electromagnetic force compensation load cells must be regularly adjusted either with a firmly incorporated (internal) adjusting weight or with an external mass standard. Electromagnetic force compensation load cells are,

however, also used in industrial and commercial weighing instruments (class III) with maximum loads of up to 10 t. From maximum loads of approx. 10 kg to a maximum load of approx. 50 kg, direct loading is no longer possible and hybrid designs with lever systems must be chosen to limit relative measurement uncertainties to slightly less than $1 \cdot 10^{-4}$ [2, 15]. The upper limit of approx. 10 t is justified by the fact that, in the case of higher loadings, the conditions of use are often no longer stable enough and also that mass standards having the required accuracy for adjustment are no longer available. Electromagnetic force compensation load cells are particularly suited for being used in automatic weighing instruments with dynamic weighing, such as automatic checkweighers. In the range from approx. 10 g to 5 kg, especially monolithic designs with integrated stay and lever systems as well as overload springs with resolutions of up to 10^5 scale intervals have proved themselves. Also for so-called “multi-interval weighing instruments” [1, 19], electromagnetic force compensation load cells are very well-suited.

3 Non-automatic weighing instruments

Non-automatic weighing instruments (NAWI) are in most cases subject to legal control due to their importance in commercial transactions, i. e. they underlie strict legal prescriptions. For NAWIs, for example, the European Directive 90/384/EEC [18] is applicable, which has been transposed into German national legislation via the Verification Ordinance [17] in combination with the harmonised European Standard DIN EN 45501 [19]. Furthermore, Recommendation R76 [1] of the International Organisation for Legal Metrology (OIML) and the Guides of the European Cooperation in Legal Metrology (WELMEC) are to be taken into consideration [6, 20]. Thus, for type examinations of NAWIs, not only the measurement deviations at different temperatures (generally -10 °C to $+40$ °C) and the different ambient humidity rates are determined but also, e. g., the reproducibility (repeatability), the discrimination, the sensitivity, the creep, the error in the case of eccentric loading, the electromagnetic compatibility, the long-term stability (span stability) and the influence of tilting. Figure 6 shows examples of typical measurement deviations and maximum permissible errors of a balance for trade purposes having a maximum capacity of $\text{Max} = 15$ kg at different temperatures. For comparison purposes, also the 0.7-fold lower maximum permissible error for the respective load cell is shown.

For the type approval of NAWIs in Germany, PTB is the responsible authority – and here in particular the Department “Mass” in cooperation with the PTB’s certification body. A description

of all metrological tests prescribed for NAWIs can be found, for instance, in the OIML Recommendation R76 [1].

NAWIs which are subject to legal control are classified – depending on the so-called verification scale interval e and the number of scale intervals n – into four accuracy classes:

- Special accuracy (class I);
- High accuracy (class II);
- Medium accuracy (class III);
- Ordinary accuracy (class IIII).

The verification scale interval e is a reference value in a unit of mass which is characteristic for the maximum permissible error of the weighing instrument. In the case of medium accuracy and ordinary accuracy scales, e is equal to the digital scale interval d ; in the case of special accuracy and high accuracy balances, $d \leq e$.

Figure 7 shows the accuracy classes I to IIII for non-automatic weighing instruments as a function of the verification scale interval e , the number of verification scale intervals n and the maximum capacity Max .

Balances of special and high accuracy balances are often classified under the generic term of “laboratory balances” and, depending on their readability and their maximum capacity, designated as ultra-micro, micro, semi-micro and macro balances. Table 1 shows the classification of laboratory balances.

Table 1: Classification of laboratory balance

Designation	Scale interval d	Maximum capacity Max
Ultra-micro balance	0.1 μg	$\leq 5 \text{ g}$
Mikrobalance	1 μg	1 g ... 25 g
Half-micro balance = semi-micro balance	10 μg	30 g ... 200 g
Macro balance = analytical balance	0.1 mg	50 g ... 500 g
Precision balance	$\geq 1 \text{ mg}$	$\geq 100 \text{ g}$

Figure 8 shows a selection of commercially available laboratory balances with maximum capacities between 50 g and 8 kg.

NAWIs comprise an exceptionally wide range of types and scopes of application. Here are a few examples (in brackets, the corresponding accuracy class(es) and typical maximum capacities):

- Laboratory balances (I and II / 2 g to 2 kg);
- Scales for direct sales to the public and price-labelling instruments (III / 6 kg to 15 kg);
- Platform scales for trade and industry (mainly III, partially II / 1 kg to 3 t);
- Hopper weighers (III / 100 kg to 300 t);
- Weighing instruments for hanging loads, e.g. crane and mono-rail suspension weighers (III / 0.1 kg to 400 t);

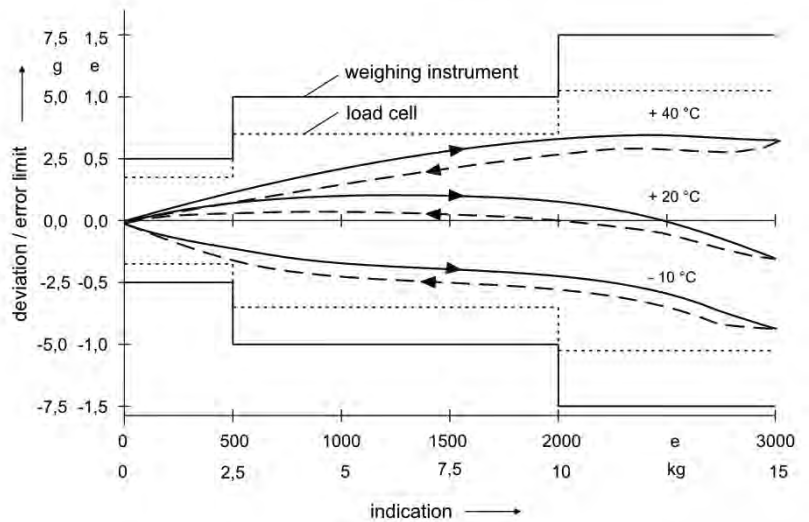

Figure 7: Accuracy classes I to IIII of non-automatic weighing instruments as a function of the verification scale interval e , the number of verification scale intervals n and the maximum capacity Max .

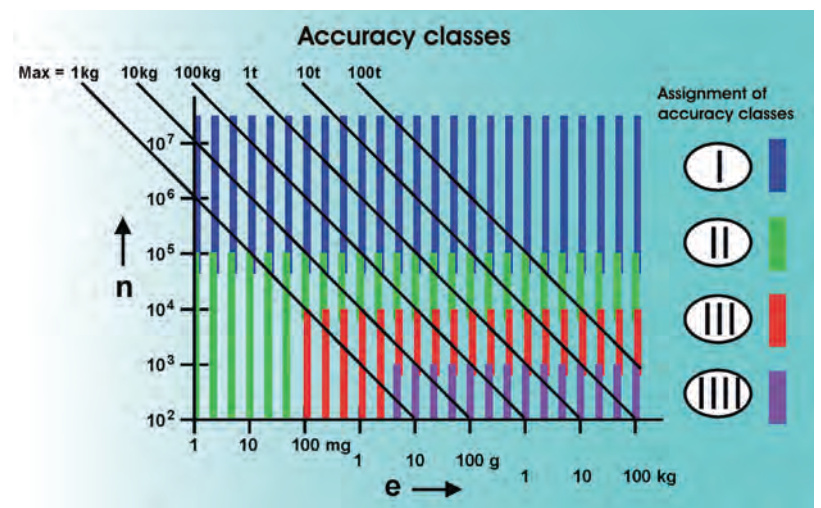

Figure 6: Examples of typical measurement deviations and maximum permissible errors of a balance for trade purposes having a maximum capacity of $Max = 15 \text{ kg}$ at different temperatures. For comparison purposes, also the 0.7-fold lower maximum permissible error of the respective load cell is shown (dashed); e = verification scale interval [1, 19].

- Weighing instruments for the determination of fares, e.g. letter scales and luggage weighers (III / 1 kg to 100 kg);
- Person scales for medical applications, e.g. bed, chair and baby scales (III / 10 kg to 200 kg);
- Weighing instruments for road and rail vehicles (III / 20 t to 100 t);
- Mobile weighing instruments, e.g. in pallet and fork lifters (III / 500 kg to 25 t);
- Building material weighing instruments and ordinary-accuracy scales for the weighing of waste (III / 0.3 t to 30 t);
- Axle load weighers (wheel load weighers) (III / 0.3 t to 20 t).

Figure 8:

Selection of commercially available laboratory balances with maximum capacities between 50 g and 8 kg (the photograph is the property of Sartorius AG).



An overground version of a road vehicle weigher for the weighing of trucks of up to 100 t is shown in Figure 9.



Figure 9:

Overground version of a road vehicle weigher for the weighing of trucks of up to 100 t (the photograph is the property of Schenck Process).

4 Automatic weighing instruments

Also automatic weighing instruments (AWIs) are generally subject to legal verification in Germany – as in most EU countries. For AWIs, the European Measuring Instruments Directive 2004/22/EC (the so-called “MID”) [21] has been valid since 2006; in Germany, it has been transposed into national law through the Verification Ordinance. Furthermore, there are several OIML metrological recommendations for AWIs [22–27] as so-called „normative documents“ according to the MID, and certain WELMEC guides have to be observed [28–31] in the same way as in the case of NAWIs. Besides the requirements for static operation, most AWIs must, in addition, fulfil the requirements for dynamic weighing operation. For example, modern automatic checkweighers subject to legal control (maximum capacities ≤ 100 kg) achieve relative measurement uncertainties of approx. $1 \cdot 10^{-3}$ in the case of dynamic weighing operations involving up to 100 packages per minute.

Also for AWIs, a multitude of designs and measuring principles exist, such as belt weighers (CT), automatic weighing instruments which

determine the mass of pre-assembled discrete loads (ACI), automatic checkweighers (CW), automatic rail-weighbridges (RW), automatic road vehicle weighers (ARV) for weighing whilst in motion, automatic gravimetric filling instruments (AGFI), as well as totalizing hopper weighers (DT). As regards the market value of the weighed products, CT, DT, CW and AGFI are the balances with the largest significance for the economy and will therefore be introduced briefly in the following. For the other variants, please refer to the bibliography [12, 32].

4.1 Belt weighers (CT)

CTs – also called “continuous totalizing automatic weighing instruments” – are AWIs dedicated to the continuous weighing of bulk products (mass products) on a conveyor belt without a systematic subdivision of the mass and without interruption of the movement of the conveyor belt. Continuous, totalizing weighing implies a continuous measurement of the load q applied to the conveyor belt (e. g. in kg/m) and of the belt speed v (e. g. in m/s). The multiplication of q times v yields the mass flow (e. g. in kg/s), whose time-dependent integration yields the mass m to be determined (e. g. in kg). Figure 10 depicts a belt weigher.

CTs are used especially for the bulk-to-bulk weighing of coal, ore and other raw materials in heavy industry, e. g. in harbours and underground mines as well as in opencast mining. With belt weighers subject to legal control, mass flows of up to approx. 20 000 t/h and belt speeds of up to 5 m/s can be measured with relative uncertainties of 0.5 % to 1 %.

4.2 Totalisierende Behälterwaagen (SWT)

Totalizing hopper weighers - also called „discontinuous totalizing automatic weighing instruments“ – are AWIs which weigh bulk products (mass products) successively by dividing them into discrete loads, whereby the mass of each discrete load is determined in sequence and summed. Each discrete load is then returned to the bulk. DTs are used when a higher accuracy



Figure 10:
View of a belt weigher (the photograph is the property of Schenck Process).

than the one achieved with belt weighers is required. A typical application is the determination of the mass of valuable bulk products such as cereals being unloaded from.

4.3 Automatic checkweighers (CW)

Automatic checkweighers are ACIs which check certain items – generally prepackages of the same nominal quantity – to find out whether the actual weight of a package is in compliance with the declared mass (the nominal quantity) within the admissible tolerance. Packages which lie outside the admissible tolerance are automatically sorted out. Static as well as dynamic weighing operations can be carried out. Automatic checkweighers are generally equipped with additional statistical functions such as the calculation of average values and standard deviations for the surveillance and control of filling processes.

Automatic checkweighers are of great importance for the production of finished products such as food, spray cans and tablets. Figure 11 shows a commercially available automatic checkweigher.

The most essential components are the feeding conveyor belt, the belt for the separation (singling) of the items, the conveyor belt for the weighing operation, the discharge conveyor belt and the sorting device by means of which packages lying outside the tolerance range are sorted out. CWs usually have maximum capacities of less than 100 kg and achieve weighing rates of more than 400 packages per minute. Depending on, e.g., the speed of the belt, the mechanical set-up, the load cells used and the shape and content of the packages, it is possible to achieve relative uncertainties of 0.1 % and less.



Figure 11:
View of a commercially available automatic checkweigher with conveyor belt for dynamic weighing (the photograph is the property of Sartorius AG).

4.4 Automatic Gravimetric Filling Instruments (AGFI)

Automatic gravimetric filling instruments – also called “filling weighers” – are AWIs with which certain pre-determined quantities of a bulk product (mass material) are filled from a supply quantity into containers or packages. Contrary to ACIs, in the case of AGFIs, the filling process (weighing) is the main part of the procedure, i.e. the aim is to achieve exactly the pre-determined nominal quantity which is often already printed on the package. Therefore, besides one or several weighing units, also the automatic feeding or dosing units and the required adjustment, control and discharge devices are essential parts of AGFIs.

AGFIs play an essential role not only in the food industry but also in the non-food industry, i.e. everywhere where bulk products or liquids are filled from containers, tanks, silos or mixing units into packages, sacks, cans or crates of a pre-determined nominal mass. There are numerous products which are filled into prepackages by automatic gravimetric filling instruments, for example food, cereals, milk powder, animal feed, liquids, agricultural products, chemical or pharmaceutical products, and construction material. Figure 12 shows a modern AGFI with a high-speed packaging line and a rotating carousel.

Automatic gravimetric filling instruments generally have maximum capacities between 1 kg and 50 kg; there are, however, also weighing and sack-filling machines for large sacks with a capacity of 200 kg and more. AGFIs allow relative uncertainties of 1 % to be achieved – depending on the filling quantity and the product, these can lie clearly below 1 %.



Figure 12:
Modern AGFI with a high-speed packaging line and a rotating carousel (the photograph is the property of Chronos Richardson).

New developments in the area of automatic weighing are mostly taking place in the field of mobile weighing and weighing whilst in motion. Furthermore, clear trends towards the integration of non-automatic weighing instruments into automatic industrial processes can be observed.

5 International harmonisation

Due to their significance in trade and international business transactions, it is not surprising that weighing instruments are the category of measuring instruments being best harmonised worldwide. Harmonisation in the field of metrology – also and particularly in legal metrology – basically implies the two following aspects:

- Adaptation of national **requirements** for measuring instruments to regional or international regulations and recommendations, e.g. European directives or OIML recommendations;
- Application of internationally uniform **testing procedures** and **test reports**.

Either way, it is the objective of harmonisation to save time and money by avoiding redundant testing and reducing technical barriers to trade whilst keeping the level of metrological tests constantly high.

At the European level, this development is considerably advanced by EU directives according to the so-called “New Approach” and “Global Approach”. The Weighing Instruments Directive 90/384/EEC [18] for non-automatic weighing instruments is such an EU directive which was implemented as early as in 1993, when the single European market was introduced. Since then, there have only been European type approvals for NAWIs. NAWI manufacturers can freely choose the European “notified body” where they want to submit their application for such an European type approval.

Since October 30, 2006, this has also been valid for AWIs. Since then, the European Measuring Instruments Directive 2004/22/EC [21] (which is just called “MID” in expert circles) has been used, which applies the regulations of the “New Approach” and of the “Global Approach” to nine other categories of measuring instruments besides AWIs.

In order to avoid competitive distortions amongst the “notified bodies” and to ensure an, as far as possible, harmonised implementation of the MID, the European Legal Metrology Cooperation (WELMEC) was founded in 1990 to represent European cooperation in the field of legal metrology. WELMEC permits a permanent, regular exchange on certain issues concerning measuring instruments, but also on issues which go beyond that, such as, e.g., the execution of software tests. To deal with this issue in particular and just in time to accompany the release of the MID, WELMEC Guide 7.2 was published [31]; it deals with all the main requirements for the software examinations of MID measuring devices, hence also of AWIs. For NAWIs, the special software guide 2.3 is still valid [29].

Also at an international level, the harmonisation of the provisions and testing procedures for NAWIs and AWIs has been considerably brought forward thanks to the work done by the OIML Working Groups TC9/SC1 and TC9/SC2 in the last few years. The worldwide most important OIML Recommendation R76 for NAWIs, which was already published in 1992, has now been revised and adapted to the current state-of-the-art technology; since the end of 2007, it has been available on OIML’s website and can be downloaded free of charge. Also for all types of AWIs, the highest possible metrological standard has meanwhile been defined by means of six different OIML recommendations for applications in the field of legal metrology [22–27].

With regard to the mutual recognition of test results and test reports on the basis of the OIML recommendations, especially for NAWI weighing instruments, bilateral cooperation agreements could be concluded and implemented between PTB and certain certification bodies in Japan, China and Russia since 1999. Thus, the extended agreement with Japan signed on June 5, 2007 includes considerably higher maximum capacities than previously (Max = 5 t). Furthermore, load cells pursuant to the OIML R60 recommendation are now included, provided they comply with the specifications of the accuracy classes C and D, have maximum capacities up to 20 t, the number of verification scale intervals is max. 6000, and they have passed one of the humidity tests according to SH or CH.

6 Summary and outlook

The future of mass determination and weighing technology in legal metrology will surely be characterized by new technologies, especially in the field of software and information technology. In this context, the potential introduction of digital signatures and cryptographic methods for the verifiable transmission of weighing results via the Internet is one of the most typical examples. An important challenge in the field of metrology is the development of new sensors (load cells) for weighing technology, to be able to meet future requirements. In the "Mass" Department, research activities are already taking place within the scope of industrial cooperations in order to, e. g., investigate the suitability of novel silicon (Si) load cells for utilisation in verifiable weighing instruments. The prototype of such a load cell developed at PTB with a maximum nominal load of 6 kg is depicted in Figure 13.

In terms of metrological behaviour, the first results confirm the clearly superior material properties of Si as compared to steel or aluminium [33].

Within the scope of international cooperation, it can be expected that PTB's bilateral agreements with some non-European partner institutes will be replaced in the medium term by the new OIML Mutual Acceptance Arrangement (MAA) [34].

7 Literature

- [1] International Recommendation OIML R 76-1: Non-automatic weighing instruments, Part 1: Metrological and technical requirements – Tests. OIML, Paris, 2007
- [2] Schwartz, R.: Kraft, Masse, Drehmoment. In: *Gevatter, H.-J.; Grünhaupt, U.* (Hrsg.): Handbuch der Mess- und Automatisierungstechnik in der Produktion. Springer Verlag Berlin Heidelberg New York, 2. Aufl., 2006
- [3] Kümme, R., Illemann, J., Nesterov, V., Brand, U.: Kraftmessung von Mega- bis Nanonewton PTB-Mitteilungen 118 (2008)
- [4] Kochsiek, M.; Meißner, B.: Wägezellen – Prinzipien, Genauigkeit, praktischer Einsatz für eichfähige Waagen, Teil 1 und Teil 2. wägen + dosieren, Heft 6/1997 und 1/1998, pp. 6–16
- [5] International Recommendation OIML R 60: Metrological regulation for load cells, OIML, Paris, 2000
- [6] WELMEC 2.4 (Issue 2): Guide for Load Cells. Deutsche Fassung: Leitfaden für Wägezellen, 2. Ausgabe, 2001 [<http://www.welmec.org/>]
- [7] VDI/VDE-Richtlinie 2637: Kenngrößen für Wägezellen, Begriffe und Definitionen. VDI/VDE-Gesellschaft Mess- und Automa-
- tisierungstechnik (GMA), Beuth Verlag GmbH, Berlin, 1999
- [8] Mack, O.: Add-on of the 2-MN-Force Standard Machine for testing load cells. Proceedings of the 20th Conference on Measurement of Force, Mass and Torque (together with 3rd Conference on Pressure Measurement & 1st Conference on Vibration Measurement) Cultivating Metrological Knowledge. Merida, Mexico, 2007, ID-056
- [9] Hoffmann, K.: Eine Einführung in die Technik des Messens mit Dehnungsmessstreifen. Hottinger Baldwin Messtechnik GmbH, Darmstadt, 1987 (Neuaufkl. 2000)
- [10] Giesecke, A.: Dehnungsmessstreifentechnik. Vieweg Verlag, Braunschweig Wiesbaden, 1984
- [11] Weyhe, S.: Wägetechnik im Labor. Verlag moderne Industrie, Landsberg/Lech, Sartorius AG, Göttingen, 2. Aufl., 2001
- [12] Kochsiek, M. (Ed.): Handbuch des Wägens. Vieweg, Braunschweig Wiesbaden, 2. Aufl., 1989
- [13] Kochsiek, M.; Gläser, M. (Ed.): Massebestimmung. VCH Verlagsgesellschaft GmbH, Weinheim, 1997
- [14] Kochsiek, M.; Gläser, M. (Ed.): Comprehensive Mass Metrology. Wiley-VCH, Berlin, 2000
- [15] Kochsiek, M.; Meißner, B.: Wägesensorik – Prinzipien, Genauigkeit, praktischer Einsatz für (eichfähige) Waagen. In: *Vetter, G.* (Ed.): Handbuch Dosieren. Vulkan-Verlag, Essen, 2. Aufl., 2001, pp. 246–272
- [16] Schwartz, R., Borys, M., Scholz, F.: Leitfaden für Massebestimmungen hoher Genauigkeit. PTB-Bericht MA-80, Wirtschaftsverlag NW, Bremerhaven, 2006. English version: Schwartz, R., Borys, M., Scholz, F.: Guide to Mass Determination with High Accuracy. PTB-Bericht MA-80e, Wirtschaftsverlag NW, Bremerhaven, 2007

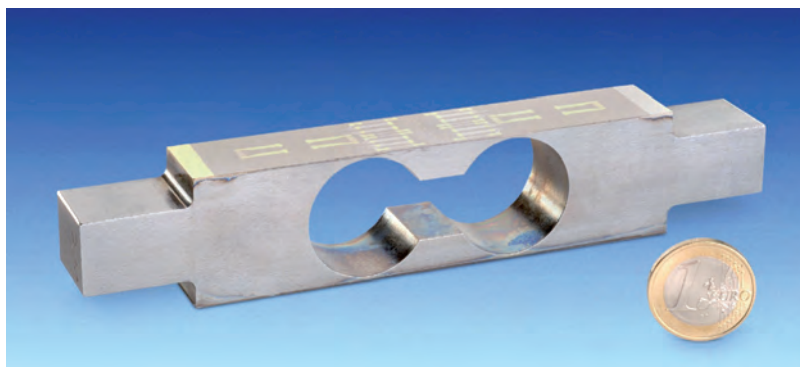

Figure 13: Prototype of a load cell with a silicon mechanical spring and sputtered-on strain gauges with a nominal load of 6 kg.

- [17] Eichordnung: Allgemeine Vorschriften mit Anlage 9 „Nichtselbsttätige Waagen“ und Anlage 10 „Selbsttätige Waagen“, 1988, zuletzt geändert durch die 4. Verordnung zur Änderung der Eichordnung vom 8. Februar 2007, Bundesgesetzblatt I, Bundesanzeiger Verlagsgesellschaft mbH, Köln, p. 70
- [18] Richtlinie des Rates 90/384/EWG vom 20.06.1990 zur Angleichung der Rechtsvorschriften der Mitgliedsstaaten über nichtselbsttätige Waagen. Amtsblatt der EG Nr. L189/1, 20.07.1990
- [19] Norm DIN EN 45501: Metrologische Aspekte nichtselbsttätiger Waagen. Beuth, Berlin, 1992
- [20] WELMEC 2 (Issue 4): Directive 90/384/EEC: Common Application, 2004
- [21] Richtlinie 2004/22/EG des europäischen Parlaments und des Rates vom 31.03.2004 über Messgeräte, Arb.-Bl. EU Nr. L 135, S. 1
- [22] International Recommendation OIML R 50-1: Continuous totalizing automatic weighing instruments (belt weighers), Part 1: Metrological and technical requirements – Tests. OIML, Paris, 1997. *German version*: DIN 8132 (Draft): Selbsttätige Waagen zum kontinuierlichen Totalisieren, Förderbandwaagen (FBW). Beuth, Berlin, 2001
- [23] International Recommendation OIML R 51-1: Automatic catchweighing instruments, Part 1: Metrological and technical requirements – Tests. OIML, Paris, 2006. *German version*: DIN 8128-1 (Draft): Selbsttätige Waagen für Einzelwägungen, Teil 1: Metrologische und technische Anforderungen – Prüfung. Beuth, Berlin, 1997
- [24] International Recommendation OIML R 61-1: Automatic gravimetric filling instruments, Part 1: Metrological and technical requirements – Tests. OIML, Paris, 2004. *German version*: DIN 8131 (Draft): Selbsttätige Waagen zum Abwägen (SWA). Beuth, Berlin, 2001
- [25] International Recommendation OIML R 106-1: Automatic rail-weighbridges, Part 1: Metrological and technical requirements – Tests. OIML, Paris, 1997. *German version*: DIN 8129 (Draft): Selbsttätige Gleiswaagen (SGW). Beuth, Berlin, 2001
- [26] International Recommendation OIML R 107-1: Discontinuous totalizing automatic weighing instruments (totalizing hopper weighers), Part 1: Metrological and technical requirements – Tests. OIML, Paris, 2007. *German version*: DIN 8130 (Draft): Selbsttätige Waagen zum diskontinuierlichen Totalisieren (totalisierende Behälterwaagen) (SWT). Beuth, Berlin, 2001
- [27] International Recommendation OIML R 134-1: Automatic instruments for weighing road vehicles in motion and axle-load measuring. Part 1: Metrological and technical requirements – Tests. OIML, Paris, 2006
- [28] WELMEC 2.1 (Issue 4): Guide for Testing Indicators (Non-Automatic Weighing Instruments), 2001; *German version*: Leitfaden zur Prüfung von Auswertegeräten, 4. Ausgabe, 2001
- [29] WELMEC 2.3 (Issue 3): Guide for Examining Software (Non-Automatic Weighing Instruments), 2005
- [30] WELMEC 2.5 (Issue 2): Guide for modular approach and testing of PCs and other digital peripheral devices (Non-Automatic Weighing Instruments), 2000; *German version*: Leitfaden zum Modulkonzept und zur Prüfung von PCs und anderen digitalen Zusatzeinrichtungen, 2. Ausgabe, 2000
- [31] WELMEC 7.2 (Issue 2): Software Guide (Measuring Instruments Directive 2004/22/EC), 2008
- [32] Schwartz, R.: Automatic Weighing – Principles, Applications & Developments. In: Osanna, P.H.; Durakbasa, M.N.; Afjehi-Sadat, A. (eds.): Proc. XVI IMEKO World Congress (IMEKO 2000), Vol. III, Wien, 2000, S. 259–267
- [33] Mäuselein, S.; Mack, O.; Schwartz, R.; Jäger, G.: Investigations of load cells made of single-crystalline silicon with sputtered-on strain gauges. Proceedings of the 20th Conference on Measurement of Force, Mass and Torque (together with 3rd Conference on Pressure Measurement & 1st Conference on Vibration Measurement). Merida, Mexico, 2007, ID-004
- [34] Basic Publication OIML B 10-1: Framework for a Mutual Acceptance Arrangement on OIML Type Evaluations. OIML, Paris, 2005

Force Measurement from Mega- to Nanonewton

Rolf Kumme¹, Jens Illemann², Vladimir Nesterov³, Uwe Brand⁴

1 Introduction

In numerous applications in research and industry, forces must be measured which are traced back to the national standards at PTB. In this article, the measurement of *static* forces will be dealt with, whereas *dynamic* forces will be the subject of the article “*Dynamic Calibration of Force Transducers*”, which is also to be found in this publication. Whilst in the past, traceability was especially required for forces larger than 1 newton, the need for traceability of smaller forces, in the milli-, micro- and nanonewton range, is constantly increasing today.

This article first gives a survey of the classic fields of application of force measurement and of the principles of PTB’s force standard machines which cover the measuring range from 1 N to 16.5 MN.

In order to meet the demand for smaller forces in the nN range, new measuring facilities have been developed and/or are presently being developed. These will be described in the following, in a section about the mN range and in a section about the nN range. In these sections, also the application possibilities for these small forces will be explained.

2 Force measurement from 1 N to 16.5 MN

The classic applications of force measurement extend from 1 N to 100 MN and are covered from 1 N to 16.5 MN for tension and compression forces by PTB’s force scale (see Figure 1). Material testing and safety engineering require measurements of forces over the complete range. In the aerospace industry, off-shore industry and in opencast mining, applications in the MN range dominate. In the medium force range from 1 kN to 1 MN, applications are found in the automotive industry, in materials handling and in aviation, whereas in the textile industry and in automation and medical engineering, forces in the lower force range of up to a few kN are measured.

PTB’s force scale covers the range from 1 N to 2 MN with deadweight force standard machines

and the upper measuring range up to 16.5 MN with force standard machines with hydraulic transmission [1, 2].

The smallest relative measurement uncertainties are 0.002% for calibrations with deadweight and 0.01% for calibrations with hydraulic transmission. These indications correspond to the PTB entries in the CMC (Calibration and Measurement Capabilities) which are published on the BIPM’s (International Bureau of Weights and Measures) website www.bipm.org.

At the Deutscher Kalibrierdienst (DKD), currently 18 calibration laboratories for the measurement of “force” and 29 calibration laboratories for the calibration of “material testing machines” are accredited and traced back to the national standard via calibrated force measuring devices (transfer force transducers). An overview of the calibration laboratories which have been accredited by the DKD and of numerous publications such as, e.g., the DKD Guidelines DKD-R3-3 and DKD-R3-9 is available at the website of the Deutscher Kalibrierdienst: www.dkd.eu [3, 4].

¹ Dr. Rolf Kumme, Head of the Solid Mechanics Department,
e-mail: rolf.kumme@ptb.de

² Dr. Jens Illemann, Working Group „Realization of Force“,
e-mail: jens.illemann@ptb.de

³ Dr. Vladimir Nesterov, Working Group „Nano Force Metrology for Tactile Sensors“,
e-mail: vladimir.nesterov@ptb.de

⁴ Dr. Uwe Brand, Head of the Working Group „Nano Force Metrology for Tactile Sensors“,
e-mail: uwe.brand@ptb.de

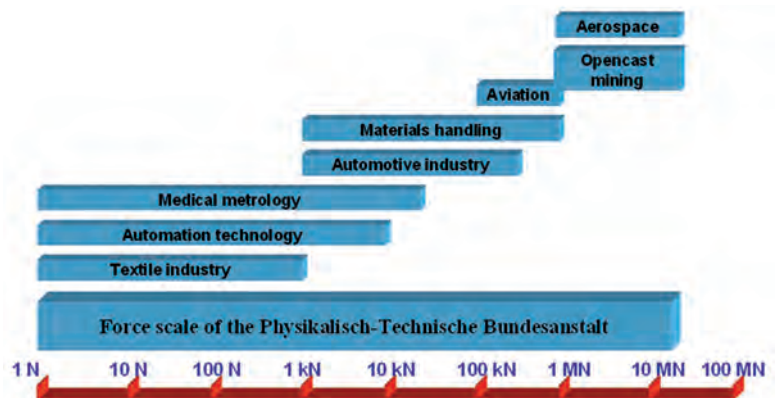

Figure 1: Industrial applications of force measurement in the range from 1 N to 100 MN

For the dissemination of the force scale, force measuring devices are calibrated and inspected in such facilities according to different procedures and standards such as, e.g., ISO 376 at different force steps, and their properties are determined [5, 6]. The force sensors are usually mechanical elastic bodies which deform under the action of a force. Most of the time, this deformation is measured electrically, e.g., according to the metrological principle of strain gauges. There are, however, other principles (e.g. piezo-electric force transducers) which generate a charge proportional to the force. For the precision measurement of static forces, e.g. within the scope of international comparison measurements, especially strain gauge force transducers (Figure 2) have established themselves, whereas dynamic measurements often require the use of piezo-electric force transducers [7, 8].



Figure 2:
The 1 MN force transducers used for the 1 MN key comparison.

2.1. Force standard machine with deadweight

In the case of force standard machines with deadweight, the force transducers are loaded with defined weight forces. Thereby, gravity in the gravitational field of the Earth acts on the deadweights and generates a vertical force which is given by:

$$F = m \cdot g_{\text{loc}} \cdot \left(1 - \frac{\rho_{\text{L}}}{\rho_{\text{m}}}\right)$$

Hereby;

m is the mass of the deadweights;
 g_{loc} is the local gravitational acceleration at the place of installation of the deadweights;
 ρ_{m} is the density of the deadweights used, and
 ρ_{L} is the density of the air.

Traceability is thus given by the mass of the deadweights and the local gravitational acceleration, taking into account the correction for air buoyancy [1, 2, 9, 10].

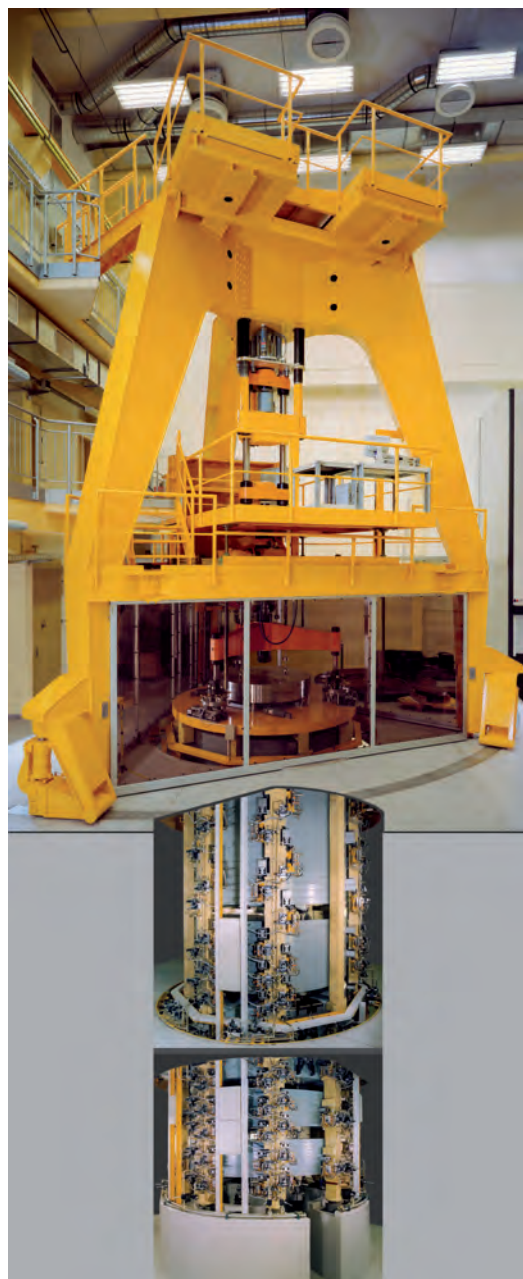

Figure 3:
The 2 MN force standard machine, which extends over 3 levels

As an example of a facility with deadweights, the 2 MN force standard machine shown in Figure 3 will be described in the following [11, 12].

Figure 4 shows a scheme of the set-up of this facility which extends over several levels and has a total height of approx. 18 m. The weight forces generated by the deadweights (13, 15, 16, 17, 18) are applied onto the force measuring device to be calibrated via a loading suspension gear (10) and a loading frame (3). The force measuring device to be calibrated is mounted between the loading frame (3) and the adjustable transverse traverse (4) of the loading suspension gear in the compression mounting space or in the tension mounting space (2 or 5, respectively).

The variable loading of the suspension frame (14) with individual weights from the five mass stacks of the 2 MN force standard machine allows the realization of individual force steps from 50 kN to 2 MN in steps of 10 kN. Thereby, the loading frame (3) is the first force step of 50 kN since, in the case of its utilisation as national standard, the taring device (9) of the 2 MN force standard machine is not used in order to keep the measurement uncertainties as low as possible.

Each of the 50 individual deadweights (13, 15, 16, 17, 18) is borne by three hydraulic cylinders each, which are mounted to the displacing device for the loading suspension gear (12) or coupled to the load suspension gear (14). An optimal centring and a vibration-proof coupling of the individual deadweights is ensured by the exact synchronisation of the respective three hydraulic cylinders.

Air bearings (19) are located at the end of two of the three tension bars of the suspension frame (14) for the frictionless prevention of transversal vibrations of the suspension frame loaded with the weights.

The 2 MN force standard machine is controlled via a pre-programmed control system (SPS) by a PC placed on the working platform. The machine is thereby designed for an automatic calibrating operation according to ISO 376.

This facility ensures traceability not only for the DKD but also for other national institutes, e. g. within the scope of EURAMET (www.EURAMET.org). Furthermore, this facility is used by PTB as a pilot laboratory for 500 kN and 1 MN in worldwide CIPM key comparisons and up to 2 MN for EURAMET key comparisons.

Figure 5 shows the relative deviation of the force transducer signal from the overall mean value measured at 500 kN and 1 MN with a 1 MN precision force transducer as a function of the mounting position of the force transducer in the 2 MN force standard machine over two full rotations of 360° each. This measurement shows that smallest possible rotation effects of < 0.001 % can be achieved by means of constructive measures even with large force standard machines. This was also proven by special investigations by means of multi-component force transducers [13].

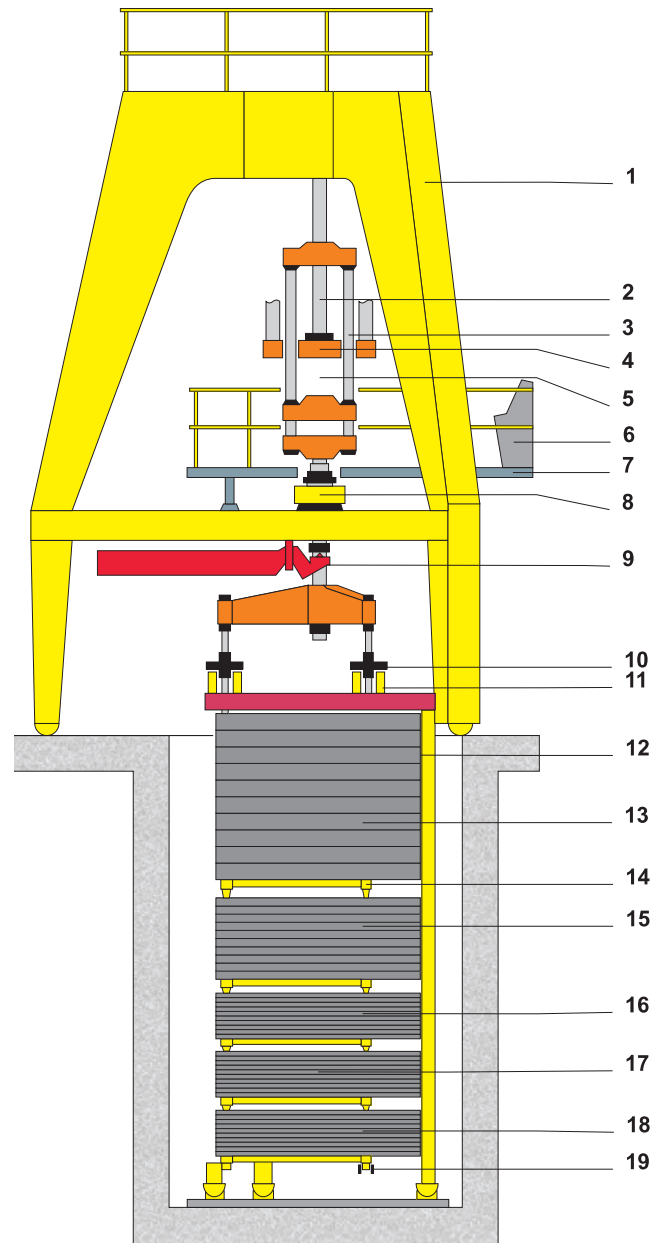
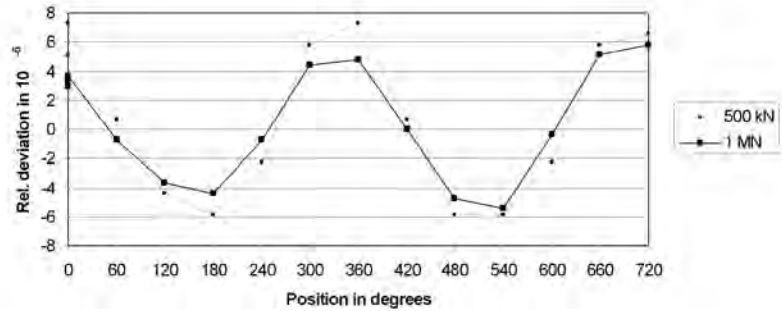

Figure 4:

Principle of the 2 MN force standard machine:

- 1 three-string supporting frame,
- 2 mounting space for compression transducers,
- 3 loading frame (50 kN),
- 4 adjustable transverse traverse of the loading suspension gear,
- 5 mounting space for tension force transducers,
- 6 control desk,
- 7 working platform,
- 8 suspension gear support for assembly work,
- 9 compensation lever,
- 10 loading suspension gear,
- 11 displacing point and centring of the suspension,
- 12 displacing support frame for the load masses,
- 13 stack 5: 10 · 100 kN,
- 14 suspension frame,
- 15 stack 4: 10 · 50 kN,
- 16 stack 3: 10 · 20 kN,
- 17 stack 2: 10 · 20 kN,
- 18 stack 1: 10 · 10 kN,
- 19 air bearing

Figure 5:
Rotation effect: Relative deviation of the force transducer signal from the overall mean value as a function of the mounting position of the transducer (in degrees) over two full revolutions for the 500 kN and the 1 MN force step.



2.2 Force standard machine with hydraulic transmission

In the case of force standard machines with hydraulic transmission, a defined weight force acts on a piston/cylinder system in which a constant oil pressure p builds up. By coupling this system with a second piston/cylinder system having a larger sectional area (pressure balance), a transmission of force by a factor $Q = A_2/A_1$ is achieved, where A_1 and A_2 are the effective areas of the two piston/cylinder systems [1, 2] (see Figure 6).

Thus, the force acting on the force transducer is given by:

$$F = Q \cdot m \cdot g_{\text{loc}} \cdot \left(1 - \frac{\rho_L}{\rho_m}\right)$$

The 16.5 MN force standard machine works according to the principle of hydraulic transmission (Figure 7) [14–16]. Thereby, the weight forces of the deadweights first act onto a piston/cylinder system at the measurement side of the facility, so that a force equilibrium is created between the weight force of the deadweights and the hydraulically generated force. The oil pressure required for this force equilibrium in this facility acts

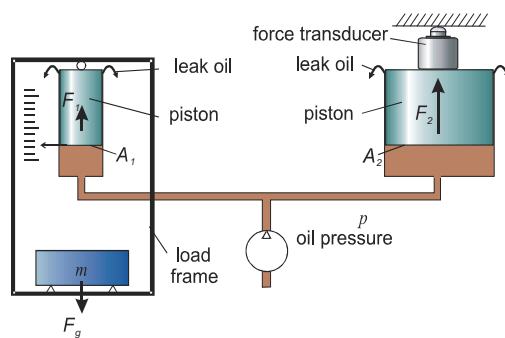

Figure 6:
Principle of the force standard machine with hydraulic transmission
 F_g is the weight force generated by the deadweights of mass m . F_1 is the force generated by the piston/cylinder system generated on the measurement side with the effective area A_1 , which is equilibrated with F_g . F_2 is the force generated by the piston/cylinder system at the operating side with the effective area A_2 , which acts on the force transducer to be calibrated.

simultaneously on four piston/cylinder systems which are arranged in parallel to each other on the operating side. Due to the ratio of the areas of the piston/cylinder systems on the operating side and on the measurement side, at equal pressure, the forces are transmitted hydraulically by a factor of approx. 1000 according to the geometric dimensions of the piston/cylinder systems of the facility. By combining the 8 deadweights on the measurement side differently, it is possible to generate 165 force steps from 100 kN to 16.5 MN in steps of 100 kN on the operating side. In Figure 7, the piston/cylinder systems on the operating side are shown on the top right; the mounting space for pressure force transducers is located in the central part of the facility and the mounting space for tension force transducers is located in the bottom part. The deadweights with the hydraulic cylinder on the measurement side are located above the concrete column in the top left part of the Figure.



Figure 7:
16.5 MN force standard machine with hydraulic transmission

2.3 Force standard machines working according to other principles

Besides force standard machines with dead-weights and with hydraulic transmission, the following other procedures are used at DKD calibration laboratories and national metrology institutes:

- force-measuring facilities with lever transmission;
- force-measuring facilities with reference transducers;
- force-measuring facility according to the build-up procedure.

In the case of force-measuring facilities with lever transmission, similar to the principle of hydraulic transmission, the force generated by direct mass effect is transmitted mechanically via a lever system [17].

In the case of force-measuring facilities operated with reference transducers, a calibrated force transducer which is mounted in the loading machine serves as a reference [18]. This represents a cheaper alternative which is used by numerous calibration laboratories in industry, but also by national metrology institutes, especially in the upper force range.

By means of the parallel coupling of several force transducers, the measuring force can be extended to even larger forces [19,20]. In this way it is, e. g., possible for a DKD laboratory to trace back forces of up to 32 MN [21].

For further information concerning the calculation of the transfer measurement uncertainty of force measuring devices, please refer to [22].

3 Force measurement in the mN range

Due to the progress achieved in microsystem technology and materials science, e. g., medical technology and hardness measurement, there is an increasing need for traceable measurements in the mN range. In order to extend the measuring range offered at PTB, a conceptionally new force standard machine was set up within the scope of a research work (Figure 8) [23].

A commercially available electromagnetically compensated balance is traced back to the SI by means of a calibration weight and of the known local acceleration [23, 24]. The scale of the electromagnetically compensated balance has been proven to be perfectly linear. The calibration is realized by direct comparison of the reaction force of a transfer force transducer on the bottom side of the electromagnetically compensated balance. For this purpose, a piezo-actuator is fixed in a defined direction to the bottom side's connector; by spreading, the piezo-actuator generates the needed force couple continuously. Any force can be realized by regulating the force

couple according to the signal of the electromagnetically compensated balance.

A precise analysis of the contributions to the measurement uncertainty for calibrations of force transducers under conditions of ISO 376 [5] was carried out on the basis of comprehensive experimental investigations [23] (Figure 9). When using the full measuring range of the electromagnetically compensated balance – a force of 2 N – the characteristic value of a sufficiently stable transducer can be determined with a relative uncertainty of $6 \cdot 10^{-6}$ (95 % coverage) and still with $2,5 \cdot 10^{-5}$ when using a partial range of 10 mN (1 mN load steps). The uncertainty for small partial ranges is mainly due to the unknown zero drift of the electromagnetically compensated balance over the duration of a calibration cycle (approx. 15 minutes).

Repeated measurements over a duration of 2 weeks were carried out (Figure 10). The axial directions of the facility were thereby partly newly adjusted and the force transducer was mounted in and out. The transducer temperature lay in an interval of 0.4 °C. As a matter of fact, the standard deviation of the measured values within 10 days is worse than the uncertainty of the measurement by a factor of 3. This is not necessarily a contradiction, since not all influence quantities having an effect on the transducer and its intrinsic stability are a priori known. In the course of further measurements over half a year, a continuous decrease of the characteristic value by 0.02 % was observed.

A very important parameter for the quality of the measurement are the mechanical coupling conditions. Since, in the case of this facility, for

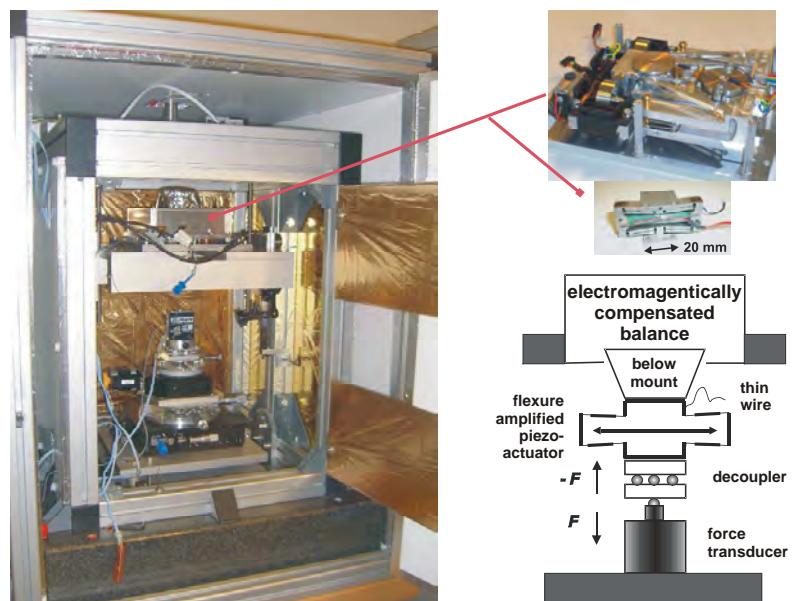

Figure 8:

Set-up and concept of the new standard measuring device for small forces. The system uses an electromagnetically compensated balance as a linear scale. Force is generated by a piezo-actuator which is firmly fixed to its underfloor connection.

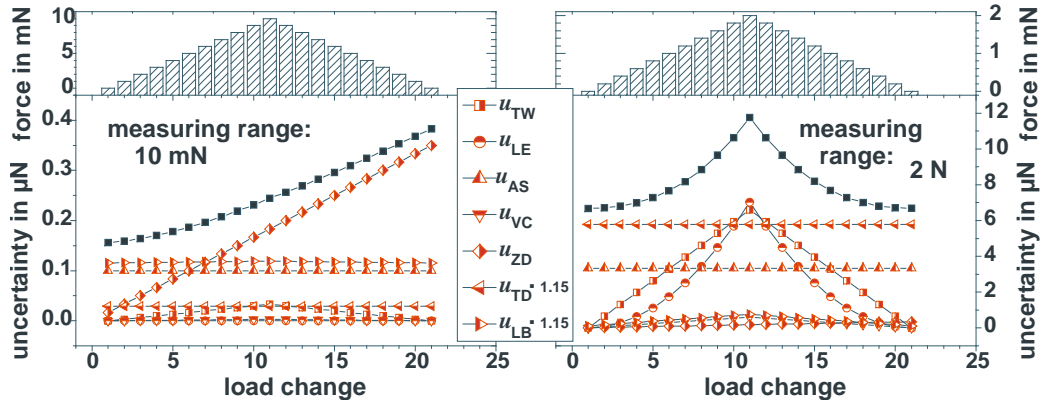

Figure 9:

Force steps and combined measurement uncertainty with 95 % coverage. The seven relevant contributions (red) and the combined measurement uncertainty (black) for a typical measurement cycle of a calibration according to ISO 376 are plotted. For a small measuring range of 10 mN, the zero drift of the balance dominates in the uncertainty budget. Uncertainty shares: u_{TW} traceability of the weight force; u_{LE} sensitivity to shearing forces; u_{AS} asynchrony of data acquisition; u_{VC} influence of the piezo voltage on the balance signal; u_{ZD} zero drift; u_{TD} time-dependence of the balance sensitivity; u_{LB} linearity of the balance.

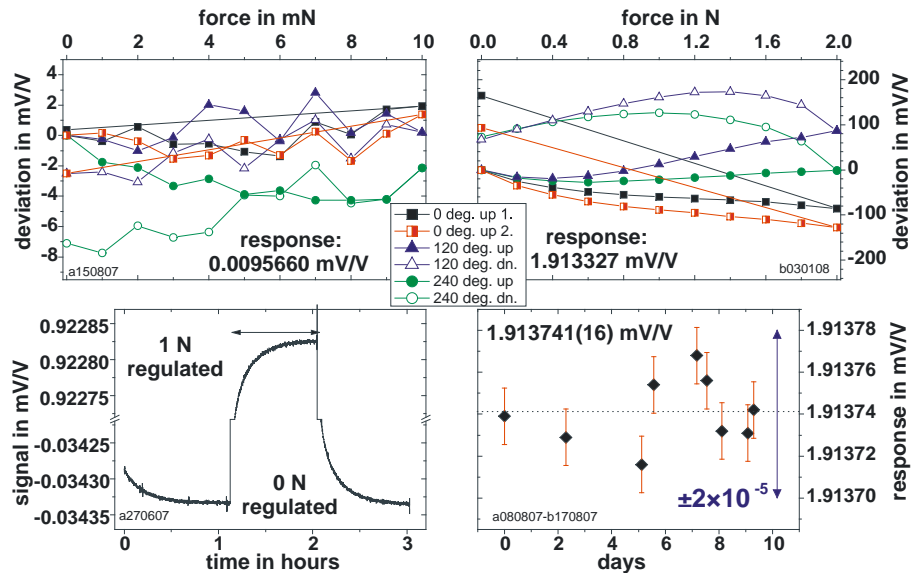

Figure 10:

Top: Calibration of a transducer according to ISO 376 over the full measuring range of 2 N and in a partial range of 10 mN. The characteristic value is yielded as the mean value of the three mounting positions at full load. Bottom right: Repeatability of the characteristic value over two weeks (measuring range: 2 N). After six months (top), it is smaller by 0.02 %. Bottom left: Measurement of the step response function. From this, the apparent hysteresis and residuum during the calibration can be predicted.

the introduction of force, constraints are given, the shearing forces and moments must imperatively be decoupled from the transducer by means of a low-friction bearing. To be able to investigate the influence of the axial directions, precise goniometers and sliding tables have been provided for this facility.

4 Force measurement in the nN range

Forces in the nano- and piconewton range have already been used for several years in scanning force microscopy for the high-resolution measurement of surfaces. The increasing industrial use of plastic microparts which get scratched when they are measured by means of contact measurements where the measuring force is too high, has led to new challenges for quality assurance for both scanning force microscopes (SFMs) and usual contact stylus instruments. For the specification

of admissible contact forces as a function of the selected stylus tip radius and the material to be measured, guidelines are required.

Furthermore, the measurement of nanoforces is important for nanomechanical investigations of the elastic properties, e. g., of single cells, but also for characterizing MEMS (micro-electro-mechanical systems) and NEMS (nano electro-mechanical systems) which have increasingly found their way into everyday products (mobile phones, MP3 players, PCs, cars).

A new field of application for scanning force microscopes has resulted from the development of automated force spectroscopy devices for molecular analysis. These devices can determine where active ingredients of medicaments bind to the target molecule and how strong the bond is. It is thus possible to measure forces in the piconewton-range.

All these measuring procedures are based on the use of soft bending test beams (cantilevers) with integrated stylus tip. The force to be determined acting on the stylus tip leads to a deflection of the cantilever. From this deflection and from the normal spring constant of the cantilever, the acting contact force can be calculated. The relative uncertainty of the contact force measured in this way depends on the uncertainty with which the spring constant of the cantilever can be determined. With the frequently used method which consists in analysing the thermal noise of the cantilever, the measurement uncertainty of the spring constant which can be achieved is 15 % to 20 %. This value and therefore also the achievable force measurement uncertainty could be significantly reduced only by using accurately calibrated nano-force transfer standards.

For the contact force calibration of contact stylus instruments, PTB, in collaboration with the Technical University of Chemnitz, has developed force transfer standards made of silicon [25] (see Figure 11) which are now commercially available (force standard of type FS-C by SiMetricS GmbH, Chemnitz).

Furthermore, contact-force sensors on the basis of piezo-resistive Si cantilevers have been developed and investigated [26]. Similar to the use of depth-setting standards, profile measurements are carried out on the cantilevers, which permits computation of the contact force on the basis of the measured deflection and of the spring constant of the beam. The standards cover the force range from 1 N to 1 μ N. The use of the piezo-resistive force sensors is simpler since they supply a force-proportional output voltage and therefore allow force measurements on sensors having no deflection measurement possibility of their own.

The spring constant of transfer standards is calibrated by means of a micro-force measuring device [27] (see Figure 12) which is composed of a precision-displacement device (PIFOC objective nano-focusing system (Physik Instrumente (PI) GmbH & Co. KG, 76228 Karlsruhe) and of a compensation balance (Type SC2, Sartorius AG, Göttingen) with a resolution of 1 nN. In the measuring range from 20 mN to 1 nN, reproducibilities of 2.5 nN, linearity deviations of 9 nN and measurement uncertainties of 20 nN are achieved at a force of 1 μ N [28].

The uncertainty of the measured spring constant which can be achieved is limited by the uncertainty of the weight force measurement of the compensation balance.

The normal spring constant of AFM cantilevers (AFM cantilevers: ThermoMicroscopes: MLCT-EXMT-BF, Explorer-mounted, gold-coated, unsharpened) was measured in the force range of a few nN to 1 μ N. The measured spring constants deviated by more than a factor of 2 from

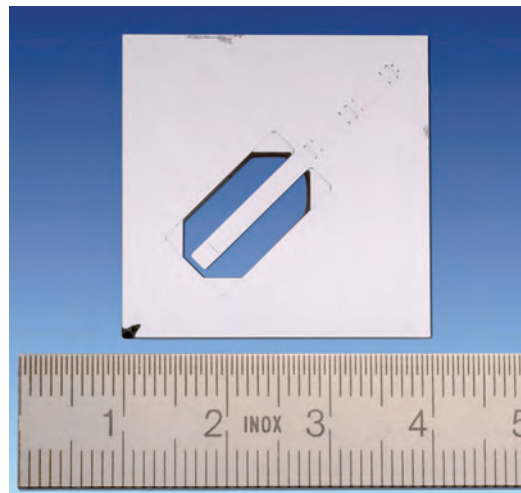

Figure 11:
Micro-force adjustment standard made of silicon (30 mm x 30 mm) with a 2 mm wide beam

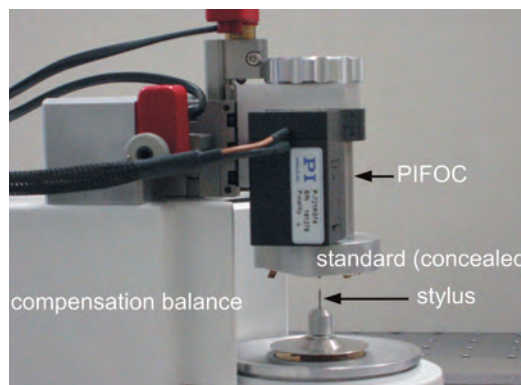

Figure 12:
Micro-force calibration facility with PIFOC, compensation balance and stylus

the stiffness calculated on the basis of geometric and physical measurands [29]. This example illustrates the importance of calibration.

For the measurement of even smaller forces – below 1 nN – e.g. for the determination of chemical bonding forces, appropriate measuring systems are currently being developed at the metrology institutes of the USA, Great Britain and Germany [30].

A nano-force measurement procedure based on a pendulum disc in vacuum with electrostatic force compensation and interferometric deflection detecting is being tested at PTB (see Figure 13) [31]. A particularity of the procedure used thereby lies in the electrostatic stiffness reduction of the disc pendulum. With voltages of $0 < U < 2$ V, it is possible to adjust stiffnesses of the disc pendulum of $3 \cdot 10^{-2}$ N/m to $3 \cdot 10^{-8}$ N/m. Stiffness reduction leads to a high sensitivity, which is necessary for small measurement uncertainties. This, however, also leads to the facility's being more sensitive to external interference quantities.

The main interference quantity of the nano-force measurement device is seismic noise. In order to reduce this influence, two practically identical disc pendulums are used – a measuring pendulum and a reference pendulum. The reference pendulum serves to measure and eliminate seismic fluctuations and thermal drift. Both pendulums are set up in the same way,

i. e. a conducting pendulum disc is suspended between two plates. Each of these external plates is composed of four ring segments, and each segment can be used as a capacitive sensor for the accurate parallel orientation of the plates relative to the pendulum disc. By means of a calibration procedure, it is possible to compute the respective compensation force from the compensation voltage. The difference between the compensation voltages of the measuring disc pendulum and of the reference disc pendulum is used to determine the applied force.

In first measurements in air over a period of 40 hours, a noise level with $\sigma < 3$ pN (σ : standard deviation, low-pass filter 10^{-2} Hz) was determined for each pendulum. After subtracting the reference signal from the measurement signal, a noise of the measured force – and thus a resolution limit of 0.16 nN – were measured (see Figure 14). This discrepancy between the noise of the measuring system and that of the individual pendulum can be mainly attributed to a relatively high asynchrony of the two pendulum systems. In an optimised set-up, based on the previously gathered experience, a more accurate nano-force measuring system in the force range from 0.1 pN to 10 μ N with an uncertainty of 1 pN at a force of 1 nN is to be developed.

5 Summary and outlook

This article describes the current status of the measurement of static forces at PTB (for dynamic forces, please refer to the article “Dynamic Cali-

bration of Force Transducers” in this publication). At present, the force standard machines cover the force range from 1 N to 16.5 MN and, thanks to the development of a new measuring system for the mN range, standards will be extended to 1 mN in the future. New measuring systems which are still under development extend into the nN range and promise metrological investigations in some fields of nanotechnology for the future.

6 Literature

- [1] Sawla, A.: Kraftskala, Messen von Kräften, Kohlrausch – Praktische Physik, Band 1, 24. Auflage, Teubner Verlag: Stuttgart 1996, pp. 133–137
- [2] Peters, M.: Derived SI-Units: Force. Teilband a: Einheiten in Physik und Chemie, Springer Verlag: Berlin 1991, pp. 2/143–2/151
- [3] DKD-R3-3: Kalibrierung von Kraftmessgeräten, Ausgabe 03/2007, www.dkd.eu.
- [4] DKD-R3-9: Kontinuierliche Kalibrierung von Kraftaufnehmern nach dem Vergleichsverfahren, Ausgabe 2/2005, www.dkd.eu.
- [5] DIN EN ISO 376:Metallische Werkstoffe – Kalibrierung der Kraftmessgeräte für die Prüfung von Prüfmaschinen mit einachsiger Beanspruchung, Beuth Verlag: Berlin 2005
- [6] VDI-Richtlinie VDI/VDE/DKD 2638, Kenngrößen für Kraftaufnehmer – Begriffe und Definitionen, Beuth Verlag: Berlin 2006
- [7] Peters, M.: Experience and results of international comparison measurements of forces up to 1 MN, PTB-Mitteilungen 99, (1989), pp. 343–350
- [8] Kumme, R.; Mack, O.; Bill, B.; Haab, H.-R.; Gossweiler, Ch.: Investigation of piezoelectric force measuring devices in force calibration and force standard machines. In: Proceedings of the 17th IMEKO TC3 Conference, 17–21 Sept., 2001, Istanbul (Türkei), pp. 92–103
- [9] Schwartz, R.: Massebestimmung mit Waagen. In: Massebestimmung, M. Kochsiek, M. Gläser, VCH Verlag: Weinheim 1997, ISBN 3-527-29352-3, pp. 249–253
- [10] Lindau, A.; Kumme, R.; Heiker, A.: Investigation in the local gravity field of a force laboratory of PTB, Proceedings of the Joint International Conference IMEKO TC3/TC5/TC20, Celle 2002, pp. 589–598
- [11] Peschel, D.; Kumme, R.; Mauersberger, D.; Peters, M.: PTB’s “new” 2 MN dead weight force standard machine. In: Proceedings of the IMEKO TC3 Conference, 19–23 Febr., 2005, Cairo (Egypt)
- [12] Dietrich, M.; Hasche, K.; Peschel, D.: About the uncertainty of the higher capacity primary standard and the dissemination of

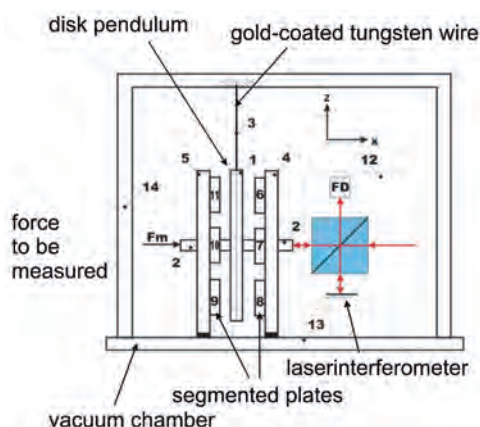

Figure 13:
Diagrammatic sketch of
PTB's nano-force meas-
uring system

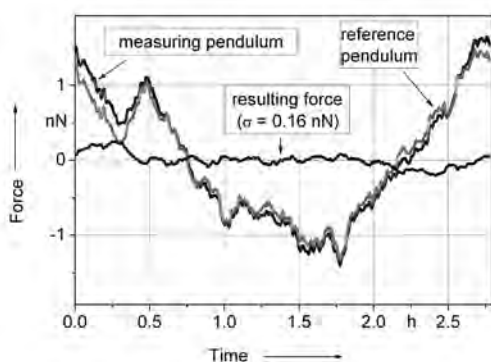

Figure 14:
First measurements of
the nano-force measur-
ing system's noise

- force in ASMW. Proceedings of the 11th IMEKO Conference, Amsterdam 1986, pp. 217–226
- [13] Ferrero, C.; Marinari, C.; Kumme, R.: Investigation of parasitic components in PTB's 2 MN deadweight machine by using the INRIM six-component dynamometer. In: Proceedings of the IMEKO XVIII World Congress, 17–22 Sept., 2006, Rio de Janeiro (Brazil)
- [14] Weiler, W., Sawla, A., Peters, M.: Design and Calibration Problems of the 15 MN Hydraulic Force Standard Machine, VDI-Bericht 212 (1974)
- [15] Peters, M.: Developments and Realization of a new control principle for the 16,5 MN Force Standard Machine at PTB, Proceedings of the 12th IMEKO World Congress, Beijing (China), 1991
- [16] Peters, M.: Influences of the uncertainty of force standard machines with hydraulic multiplication, Proc. of the 13th IMEKO TC3 International Conference on Force and Mass Measurement, Helsinki, Finland, 1993, pp. 11–19
- [17] Sawla, A.; Peters, M.: M.: Realisation of force unit by means of different types of hydraulic and lever amplification machines. Proc. of the Advanced school of Metrology, Canela RS, Brazil, 1997, pp. 97
- [18] Ferrero, C.; Marinari, C.; Kumme, R.; Herte, W.: PTB and INRIM high force intercomparison up to 9 MN. In: Proceedings of the IMEKO XVIII World Congress, 17–22 Sept., 2006, Rio de Janeiro (Brazil)
- [19] Fank, S.; Kumme, R.; Bülent, A.; Ercan, P.; Glöckner, B.; Haucke, G.: Intercomparison of 3 MN hydraulic build-up and 1.1 MN lever amplification force standard machine between UME and PTB. In: Proceedings of the IMEKO XVIII World Congress, 17–22 Sept., 2006, Rio de Janeiro (Brazil)
- [20] Anderegg, P.; Honegger, W.; Sennhauser, W.; Kumme, R.; Sawla, A.: Development and calibration of a build-up system for forces of up to 21 MN. In: Proceedings IMEKO TC3/APMF'98 of the 16th International Conference on Force, Mass and Torque Measurement, 14–18 Sept. 1998, Taejon (Südkorea), pp. 45–53
- [21] Marinescu, A.; Dumbrava, I.; Opran, Gh.; Sawla, A.; Peschel, D.; Peters, M.: Accreditation of a romanian 32 MN force calibration laboratory within DKD. Proc. of the 16th IMEKO TC3/APMF '98 International Conference on Force, Mass and Torque Measurement, Taejon (Südkorea), 1998, pp. 366–375
- [22] Sawla, A.: Uncertainty scope of the force calibration machines, Proceedings of the IMEKO World Congress, Wien 2000
- [23] Illemann, J.: The achievable uncertainty for balance-based force standard machines in the range from micronewton to newton, Proc. of the Joint Int. Conf. IMEKO TC3/TC16/TC22, Merida, Mexico, 2007
- [24] Niehe, S.: A New Force Measuring Facility from the Range of 10 mN to 10 N, Proc. of the XVII IMEKO World Congress, Dubrovnik, 2003, pp. 335–340
- [25] Frühauf, J.; Trumpold, H.: Silicon Standards for Assessment and Calibration of Stylus Probes. Proceedings of 52nd CIRP General Assembly, San Sebastian, Spain, 2002
- [26] Behrens, I.; Herold, B.; Doering, L.; Peiner, E.: Piezoresistive cantilever as portable micro force calibration standard. Journal of micro-mechanics and microengineering Vol. 13, 2003, pp. 171–177
- [27] Doering, L.; Peiner, E.; Behrens, I.; Brand, U.: Calibration of micro force setting standards using a new nano force calibration device. Proceedings of Micro system technologies MST, Forum Hotel München, 2003, pp. 492–494
- [28] Peiner, E.; Doering, L.: Force calibration of stylus instruments using silicon microcantilevers, Sensors and Actuators A, Vol. 123–124, 2005, pp. 137–145
- [29] Doering, L.; Brand, U.: Calibration of V-shaped Cantilever for Micro Force Metrology in Biomedical Engineering, Proc. Euspen, 2006, pp. 192–195
- [30] Pratt, J. R., Kramar, J.A., Newell, D.B., Smith, D.T.: Review of SI traceable force metrology for instrumented indentation and atomic force microscopy, Measurement Science and Technology Vol. 16, 2005, pp. 2129–2137
- [31] Nesterov, V.: Facility and methods for the measurement of micro and nano forces in the range below 10^{-5} N with a resolution of 10^{-12} N (development concept). Measurement Science and Technology, Vol. 18, 2007, pp. 360–366

Dynamic Calibration of Force Transducers

Michael Kobusch¹, Thomas Bruns², Rolf Kumme³

1 Introduction

As a result of the increase in practical dynamic applications and increased requirements for measurement accuracy, the measurement of time-variable forces has recently become very important. In many fields of industry – for example in production engineering, destructive material testing, automation and handling engineering, vibration tests of satellites in the aerospace industry, crash tests and component tests in the automobile industry – dynamic forces must be measured with high accuracy. Depending on the application, the time-dependent course of force is very different. For example, in the case of fatigue tests, periodic forces are applied; in machining processes, step-like and continuous force changes; and in the case of crash tests, shock forces.

Force transducers are electromechanical transducers using a sensor element introduced into the force flow and generating an electrical output signal which depends on the input quantity force. Generally, the force signal is proportional to the elastic deformation of the transducer. In the case of dynamic forces, frequency-dependent inertia forces are generated in the interior of the transducer (due to material elasticities and the masses coupled to the sensor element, i.e. from the force introduction and the possibly required adaption parts) which may superimpose the input force to be measured in a disturbing way. Therefore, a frequency-dependent measurement behaviour should generally occur which is basically determined by the internal mechanical design of the force transducer [1]. Moreover, the dynamic properties of the electrical signal processing chain must also be taken into account.

The problem of measurement errors occurring in dynamic force measurements due to parasitic components is now widely known. Although current standards on instruments used in crash tests (ISO 6487 [2], SAE J211/1 [3]) specify error limits for the amplitude response of measurement transducers which must generally

be met, they, however, point out that satisfying methods for the dynamic calibration of force transducers are not yet known. Whereas the static calibration of force transducers is specified by international standards (DIN EN ISO 376, [4]), corresponding standards for the calibration of dynamically loaded transducers are still missing. It is, therefore, common practice to calibrate dynamically used force transducers only statically. At best, some dynamic force measurements on a suitable testing device are performed in addition. Such tests are well suited for comparison tests and are, therefore, widely used in industry, as they provide information about whether – and to what extent – the dynamic measuring behaviour of a force transducer has changed in the course of time and if the transducer must be replaced.

In view of the manifold dynamic applications with very different force signals, the question arises under which conditions dynamic effects must be taken into account. The most interesting aspect here is whether a dynamic force measurement can still be performed with statically calibrated characteristics or whether the required measurement uncertainty is exceeded by disturbing inertia forces. A realistic indication of the acting dynamic forces and of the measurement uncertainties is not easy and requires knowledge of the dynamic properties of the transducer and of the measuring set-up. A first step towards the selection and assessment of dynamically used force transducers is often the knowledge of the basic resonance frequency. This characteristic parameter which is relevant to dynamics is mentioned in the German Directive VDI/VDE 2638 [5] on characteristics for force transducers. Additional information about the dynamic suitability of a force transducer is offered by data on stiffness and mass.

Motivated by the increasing importance of dynamic calibrations and the – at present – metrologically unsatisfying situation, increased research efforts for the development of scientifically well-founded procedures for the dynamic calibration of force transducers and the transfer

¹ Dr. Michael Kobusch, Working Group "Impact Dynamics", e-mail: michael.kobusch@ptb.de

² Dr. Thomas Bruns, Head of the Working Groups "Impact Dynamics" and "Realization of Acceleration", e-mail: thomas.bruns@ptb.de

³ Dr. Rolf Kumme, Head of the Department "Solid Mechanics", e-mail: rolf.kumme@ptb.de

of the results to the industry have been made in the past few years at the Physikalisch-Technische Bundesanstalt (PTB) (see, for example, [6, 7]). Different measuring and calibration devices with different working principles, dynamic ranges and measurement ranges have been established and used to investigate transducers of different measuring principle and structural design, taken as examples [8–10]. With all these activities, PTB is at present playing an international pioneering role in the field of dynamic force measurement.

2 Dynamic measurement methods

For dynamic calibration, sinusoidal and shock-shaped forces have the greatest practical importance. These two types of excitation which are, however, rather different in the time and frequency domain, allow the variety of dynamic force measuring tasks to be covered with relatively good practical orientation. In the case of sinusoidal calibration, sinusoidal forces of varying frequency are applied, and the amplitude and phase responses related to a reference signal are evaluated as a dynamic calibration result. In contrast to this, force pulses of defined amplitude, shape and duration are applied in the case of the shock calibration. Here, the ratio between the pulse height of output signal and input force is often the typical measurement result which on closer examination, however, turns out to be insufficient (see section 3).

Figure 1 illustrates the basic principle of the primary calibration with sinusoidal forces, and Figure 2 shows a corresponding technical realization, using – as an example – the dynamic 10 kN force standard machine of PTB, designed for frequencies up to 1 kHz [11]. An electrodynamic shaker generates a periodic base displacement of the force transducer to be calibrated

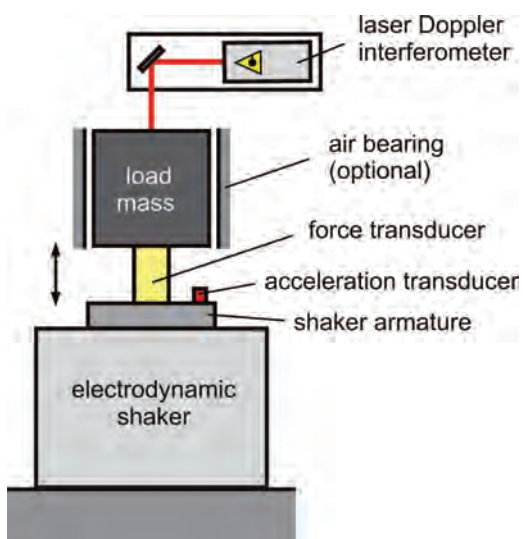

Figure 1:
Principle of the dynamic primary calibration of a force transducer with coupled load mass

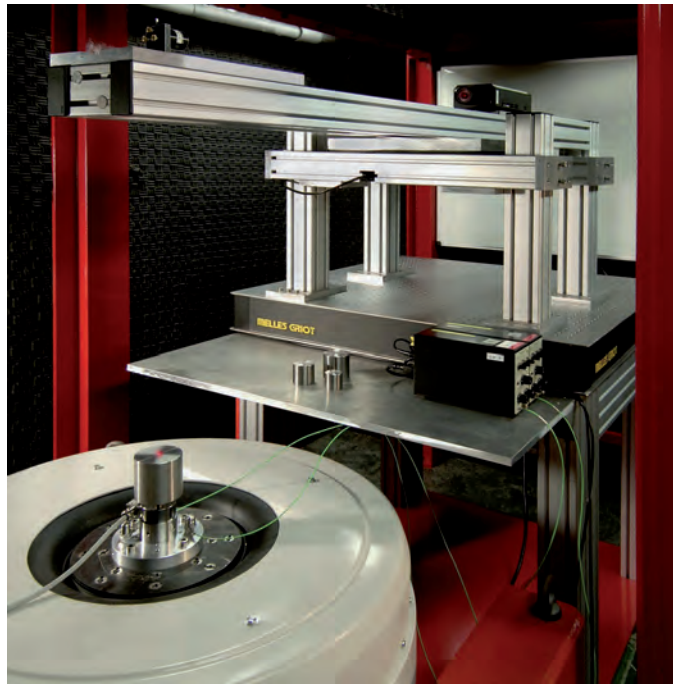

Figure 2:
Dynamic 10 kN force standard machine

which is fastened on the shaker armature. By the load mass coupled to its upper housing part, an inertia force in accordance with Newton's axiom „force equals mass multiplied by acceleration“ is generated which represents the desired dynamic input quantity. This quantity is traced back via weighing and a time-resolved acceleration measurement, e.g. by means of laser Doppler interferometry [12]. Optionally, the load mass can be run axially in an air bearing so that parasitic bending vibrations – which would otherwise occur to an increasing extent – are minimized.

In the case of higher forces and low frequencies, the above mentioned primary calibration method – which is based on the generation of inertia forces – is less suited, as disproportionately large and heavy load masses would possibly be necessary or the vibration amplitudes would become inadmissibly large. This is why a procedure generating forces by elastic deformations in a pre-stressed load frame is better suited for these requirements. The establishment of such a procedure working in accordance with the comparison method (secondary calibration) is shown in Figure 3. The force transducer to be calibrated, a reference force transducer and a hydraulic shaker are mechanically connected in series in a load frame. Via a vertically adjustable traverse, the installation height can be adapted to the respective requirements. The technical realization of this secondary calibration method is shown in Figure 4, using the example of PTB's dynamic 100 kN force standard machine which is designed for sinusoidal forces up to 100 Hz.

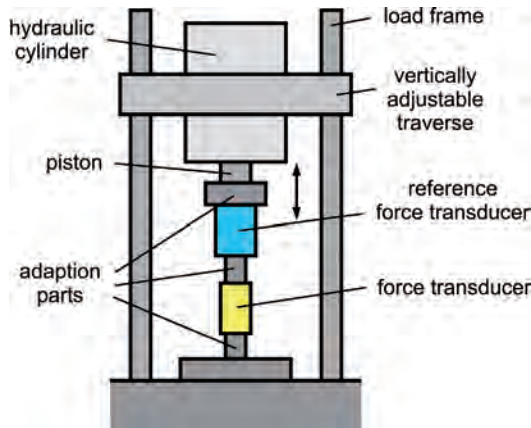

Figure 3:
Principle of the dynamic secondary calibration of a force transducer in a pre-stressed load frame

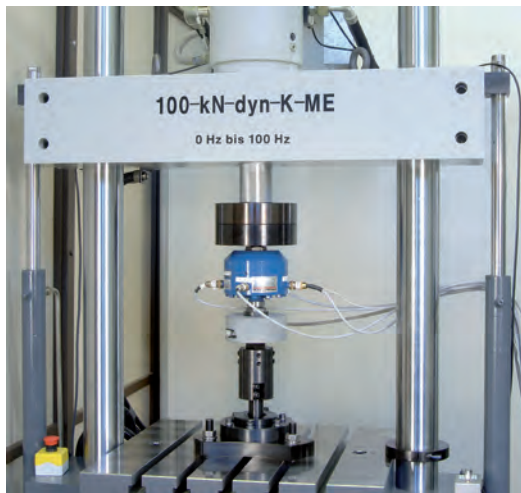

Figure 4:
Dynamic 100 kN force standard machine

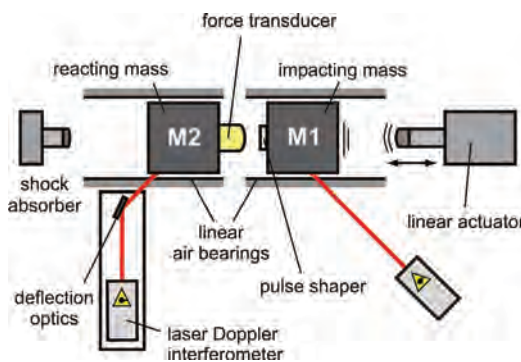

Figure 5:
Principle of the primary shock force calibration with airborne impact bodies

For primary calibration with shock-shaped forces, a measuring device with two airborne impact bodies (10 kg mass each) was developed [7, 13, 14]. Figure 5 shows the principle of the measuring set-up, a photo of the realized 20 kN impact force standard machine is shown in Figure 6. The mass body M1 accelerated to the desired impact velocity by a linear actuator impacts on the force transducer fastened on mass body M2 which is initially at rest with it. During the impact, the impulse is transmitted to the pushed body and the occurring inertia forces are detected with high temporal resolution by means of laser Doppler interferometers (LDIs). For this purpose, the mass bodies are probed by the LDI under an oblique angle at the optically accessible

side faces. The impact duration achieved in the device is of the order of one millisecond, depends on the stiffness of the transducer and can be varied by means of an inserted pulse shaper. At present, a second shock calibration device for forces up to 250 kN is being developed and installed at PTB. The new device is operated with clearly larger impact bodies of 100 kg mass each and will thus also allow heavier transducers to be adapted and calibrated.

3 Characterization of force transducers

A focal point of recent research is the characterization of force transducers for dynamic applications. Based on the parameter of the static sensitivity, additional transducer-specific data is required for dynamic calibrations. Suitable dynamic parameters provide the user with a basis to estimate the dynamic measurement properties of a force transducer in a concrete application and to judge its suitability.

The set of dynamic parameters to be determined should be suitable for all measurement principles and force transducer designs and should be, in addition, independent of the calibration procedure selected so that calibrations with, for example, sinusoidal or shock excitations yield consistent results. Transferable experience from shock calibrations of acceleration transducers shows, however, that consistency is not imperatively guaranteed – even for identical measurement procedures – when different measurement devices are used [15]. The parameter shock sensitivity for the shock calibration of acceleration transducers specified in the current standard ISO 16063-13 is determined from the time signals as the ratio between output and input peak values [16]. This ratio is, however, a function of the spectral components of the shock, i. e. it depends on the shape and duration of the shock pulse. Measurements of different measuring set-ups are, therefore, comparable only to a limited extent. As this dependence on the respective calibration conditions is not desired, PTB has taken up the further development of the shock calibration procedures for force and acceleration as a current research topic [15, 17].

As has already been mentioned in the introduction, the basic resonance frequency of force transducers has been adopted as a dynamic parameter in Directive VDI/VDE 2638 [5]. This quantity characterizes the frequency with which a transducer which is rigidly mounted on its support and used without additionally coupled components vibrates along its measuring axis after a shock excitation. Experimental investigations on differently designed force transducers which take measurements with strain gauges have shown that it is not that easy to determine the basic resonance frequency, as the signatures

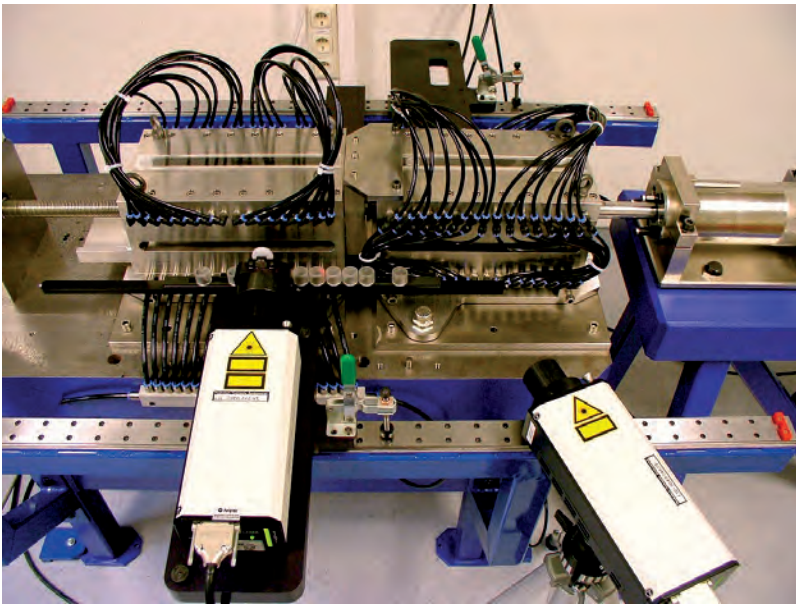

Figure 6:
20 kN impact force standard machine

of parasitic transverse and bending resonances often superimpose each other in the measuring signal in a disturbing way [9]. To estimate the influence of internal inertia forces on the dynamic measuring behaviour of the force transducer, it is not sufficient to indicate the basic resonance frequency. It is rather necessary to know the structural distribution of masses and stiffnesses in the interior of the transducers.

The investigations into the dynamic calibration performed on different measuring set-ups and with different piezoelectric and strain gauge force transducers [1, 8–10] have shown that the dynamic measurement behaviour of a uniaxial force transducer can be well described with a model of spring-coupled mass bodies. In this model, the coupling of the transducer to its mechanical environment must be adequately taken into account. Mathematically, this model is expressed by a system of 2nd order differential equations.

The dynamic measurement behaviour of a force transducer with a constructively well-defined mechanical spring (as in the case of strain gauge force transducers) can already be reproduced very well with a simple two-mass model [9]. This is valid for both the basic resonance frequency of the base-mounted transducer and for the response characteristic in the case of coupled load masses. The piezoelectric force transducers which are often used for dynamic measurements due to their high stiffness and high resonance frequency associated with it are not, however, equipped with a well-defined mechanical spring in the proper sense. This is why their basic resonance frequency is determined only insufficiently by a simple two-mass model and it may be necessary to take more complex models into consideration [10].

The two-mass standard model with one degree of freedom describes the force transducer as two model masses coupled via a visco-elastic spring element (see Figure 7a). There are four parameters: head and base mass m_H and m_B , stiffness k , damping d . For the example of a transducer fastened to its support, the time-dependent measuring force $F(t)$ is introduced on the upper model mass (head mass). The force-proportional elongation of the spring $x(t)$ caused by the input force represents the output signal in the model. For the modelling of a transducer incorporated in a measuring device, the parameters and input quantities of the model must be adequately adapted. For sinusoidal calibrations on the 10 kN force standard machine and shock calibrations on the 20 kN impulse force standard machine, the model variants shown in Figures 7b and 7c [18] are valid, in which attachment parts such as load buttons, adapters or load masses are now taken into account as resulting model masses m_{H^*} and m_{B^*} (in the figure highlighted in grey). As known input quantities, the measured accelerations $a_{H^*}(t)$ and $a_{B^*}(t)$ must be entered for sinusoidal calibration, and for shock calibration, the measured inertia forces $F_1(t)$ and $F_2(t)$.

The model-based parameter identification performed with real data sets finally leads to the sought model parameters of the force transducer, which shall represent the parameters for the description of the dynamic measurement behaviour [18, 19]. In the identification process, the model parameters are varied until the data sets measured by the force transducer and furnished by the model are in the best possible agreement. The model-based parameter identification procedure described in detail in [19] allows calibration results to be transferred to other measuring set-ups via an inverse calculation. The calibra-

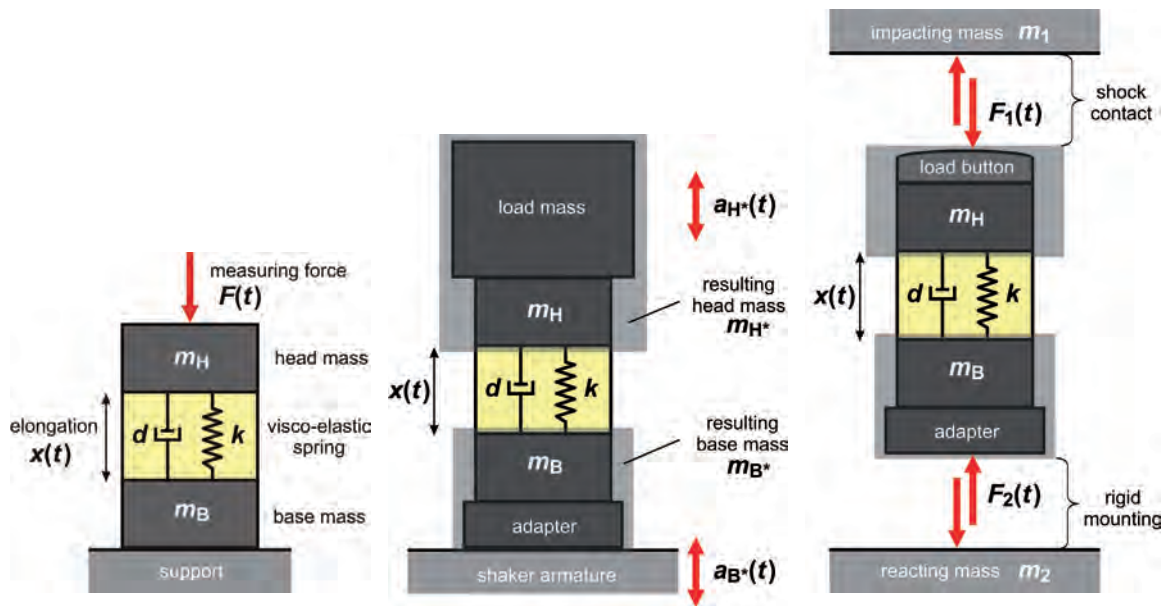

Figure 7:

Model-based characterization of the force transducer

a) standard model

b) sinusoidal calibration

c) shock calibration

tion results to be expected – such as frequency responses in the case of sinusoidal calibrations or transmission factors in the case of shock calibrations – result from the adapted model. Modelling also allows the initial question regarding the influence of the dynamic effects to be answered.

4 Summary and outlook

This article describes the current state of dynamic force measurements at PTB, an area on which research has been increasingly focussed in the past few years. Different dynamic measuring devices for shock and sinusoidal loads have been developed, and work on promising, scientifically well-founded procedures for dynamic force calibration and for the dissemination of the dynamic force scales is being performed.

Two models are discussed to transfer the results of dynamic force calibrations to the respective industrial applications. Firstly, a model-based simulation of the dynamic measuring application can be performed for a known, dynamically characterized force transducer to compensate the measured force signal. Secondly, special transfer transducers suited for dynamic measurements can be used, on whose development PTB is at present intensively working. It would, for example, be possible to compensate the frequency-dependent transmission behaviour by means of additional measuring signals so that a transfer transducer would furnish a dynamically corrected output signal.

As far as standardization activities are concerned, the know-how achieved in the field of dynamic force calibration will decisively contrib-

ute to the configuration of future standards for dynamic force measurements.

5 Literature

- [1] R. Kumme: Untersuchung eines direkten Verfahrens zur dynamischen Kalibrierung von Kraftmessgeräten – ein Beitrag zur Verringerung der Messunsicherheit, Dissertation, TU Braunschweig, 1996
- [2] International Standard ISO 6487: Road vehicles – Measurement techniques in impact tests – Instrumentation, International Organization for Standardization, Geneva, Switzerland, 2002
- [3] American Standard SAE J211-1 (R) Instrumentation for impact test – Part 1 – Electronic instrumentation, SAE International, Warrendale, USA, 2007
- [4] DIN EN ISO 376: Metallische Werkstoffe – Kalibrierung der Kraftmessgeräte für die Prüfung von Prüfmaschinen mit einachsiger Beanspruchung, Beuth Verlag Berlin, 2005
- [5] VDI-Richtlinie VDI/VDE/DKD 2638, Kenngrößen für Kraftaufnehmer – Begriffe und Definitionen, Beuth, 2006
- [6] R. Kumme: Dynamic force measurement in practical applications, Proc. of XVI IMEKO World Congress, 2000, Vienna, Austria, CD publication
- [7] Th. Bruns, R. Kumme, M. Kobusch, M. Peters: From oscillation to impact: The design of a new force calibration device at PTB, Measurement, 32 (2002), pp. 85–92
- [8] M. Kobusch, Th. Bruns, R. Kumme, Y.-K. Park: Preliminary investigations of

- dynamic responses of a multi-component force-moment sensor subject to impulse forces, Proc. of IMEKO TC3/TC5/TC20 Joint International Conference, 2002, Celle, Germany, pp. 183–191
- [9] *M. Kobusch, Th. Bruns, L. Stenner, S.-P. Schotte*: Impulse force investigations of strain gauge sensors, IMEKO TC3 19th International Conference, 2005, Cairo, Egypt, CD publication
- [10] *M. Kobusch, O. Mack, T. Bruns*: Experimentelle und theoretische Untersuchungen zum Resonanzverhalten piezoelektrischer Kraftaufnehmer, *Technisches Messen* 73 (2006) 12, pp. 655–663, Oldenbourg Verlag, München
- [11] *R. Kumme*: A new calibration facility for dynamic forces up to 10 kN, Proc. of XVII IMEKO World Congress, 2003, Dubrovnik, Croatia, pp. 305–308
- [12] *L. Zhang, R. Kumme*: Investigation of interferometric methods for dynamic force measurements, Proc. of XVII IMEKO World Congress, 2003, Dubrovnik, Croatia, pp. 315–318
- [13] *M. Kobusch, Th. Bruns*: The new impact force machine at PTB, Proc. of XVII IMEKO World Congress, 2003, Dubrovnik, Croatia, pp. 263–267
- [14] *M. Kobusch, Th. Bruns*: Uncertainty contributions of the impact force machine at PTB, Proc. of XVIII IMEKO World Congress, 2006, Rio de Janeiro, Brazil, CD publication
- [15] *Th. Bruns, A. Link, C. Elster*: Current Developments in the field of shock calibration, Proc. of XVIII IMEKO World Congress, 2006, Rio de Janeiro, Brazil, CD publication
- [16] International Standard ISO 16063-13: Methods for the calibration of vibration and shock transducers – part 13: Primary shock calibration by laser interferometry, International Organization for Standardization, Geneva, Switzerland, 2001
- [17] *A. Link, A. Täubner, W. Wabinski, T. Bruns, C. Elster*: Calibration of accelerometers: Determination of amplitude and phase response upon shock excitation, *Measurement Science and Technology*, 17 (2006), pp. 1888–1894
- [18] *M. Kobusch, A. Link, A. Buss, T. Bruns*: Comparison of shock and sine force calibration methods, Proc. of IMEKO TC3 & TC16 & TC22 International Conference, 2007, Merida, Mexico, CD publication, online at www.imeko.org
- [19] *A. Link, M. Kobusch, T. Bruns, C. Elster*: Modellierung von Kraft- und Beschleunigungsaufnehmern für die Stoßkalibrierung, *Technisches Messen* 73 (2006) 12, S. 675–683, Oldenbourg Verlag, München

Torque Measurement: From a Screw to a Turbine

Dirk Röske*

1 Introduction

In practice, torque is used so often that no one wastes a single thought about it any more. The simplest examples are surely the turning of a bottle screw cap or the opening of an ordinary door. Most of the time, it is neither necessary to measure the required torque nor to know its exact value. When it comes to, e.g., safety-related screw fittings – as is the case for wheel bolting on cars which must be loosened and tightened again twice a year to change from summer to winter tyres – it is quite different. In this case, it is of essential importance to know which torque was applied to tighten the bolts. This knowledge presupposes a measurement – which should be carried out using a calibrated torque wrench. Of course, one expects a measurement result one can trust, no matter in which garage of whatever country throughout the world the tyres have been changed. This expectation can only be fulfilled if, for these measurements, a metrological infrastructure is available and is actually used by the garage in question. Thereby, not only the measuring instruments used are of great importance, but also the experience and expertise of the users of such devices.

For the examination of torque meters, facilities are used which generate torque with the highest accuracy. Until around 1994, some industrial companies operated torque measurement facilities without having the possibility of tracing them back, i.e. without the possibility of linking them up with a “higher-value” device, a so-called “standard”, or of comparing them with such a device – since such a standard was not available in Germany at that time. PTB recognized this need and seized the opportunity to establish a torque laboratory when taking over part of the staff of the “Amt für Standardisierung, Messwesen und Warenprüfung” (Office for Standardization, Metrology and Commodities Testing) of the former German Democratic Republic (GDR) on 1 January 1991. The experience and expertise previously gathered by the employees in the field of the realization and dis-

semination of the measurand “force” could flow profitably into this new field of work. Along with new or already established solutions for special problems, the unit of torque was realized at the highest level, i.e. with minimum measurement uncertainty and over a large measuring range. Today, PTB’s torque laboratory ranks among the best in the world.

2 The two faces of torque

There are several possibilities of generating a torque. The simplest method consists in letting a force act onto the object itself or onto a suitable linking part (e.g. lever, door handle) at a certain distance from the rotation axis. Simplified, this is the equivalent of the common formulation “force multiplied by lever arm”. To be more precise, in physics, one talks about the vector, respectively the cross product of the position vector \vec{r} – from the point of rotation (or from the rotation axis) to the point of application of force – with the force vector \vec{F}

$$\vec{M} = \vec{r} \times \vec{F} . \quad (1)$$

The torque \vec{M} is, like the force, a directed quantity – i.e. a vector – which is not only characterized by its magnitude but also by its direction (location in space) and the sense of direction (clockwise or anti-clockwise). The way of realizing a torque which has just been described above has, for metrologists and testing engineers, one disadvantage: the force causing the torque is superimposed to this torque – it is not a “pure” torque but two quantities (force and torque) acting simultaneously. The objective is, however, to realize physical quantities individually and, as far as possible, uninfluenced by other quantities. Therefore, if it were possible to eliminate force without losing torque, one could then generate “pure” torque.

The solution lies in the use of two equally great forces which are directed opposite to each other. In mechanics, this is called “force couple”. Thereby, “directed opposite to each other” means that the directions are the same – i.e. the forces are parallel – but that the senses of direc-

* Dr. Dirk Röske,
Head of the Working
Group „Realization of
Torque“,
e-mail:
dirk.roeske@ptb.de

tion are different – i. e. exactly opposite to each other. If the lines of action of the two forces are not the same, a torque results which is also calculated according to (1), whereby the position vector does not start from the point of rotation now but from the point of application of the second force. The two forces compensate each other since they are equally great but directed in opposite directions. Strictly speaking, this consideration is valid only for rigid bodies – which can often be presumed.

Contrary to the case of a single force, in which one speaks of the “moment of the force” as the superposition of force and torque, the second case of force couple is also called “moment of a force couple” as the expression of a “pure torque”.

Typical applications are measurements in engine and brake test benches (force couple) or for screw connections by means of measuring or setting torque wrenches (moment of force).

3 Further aspects of the measurand “torque”

Besides its vectorial character, torque – just as force or other quantities – has further aspects which deserve closer consideration. For example, in the case of a temporally constant torque value, one speaks of “static torque”. This can, e. g., also be the case in a rotating system when the revolution speed is constant. Since motion can always be seen only relative to a defined reference system, a stationary system with zero speed is only a special case of the system with uniform motion at a speed unequal to zero. In the case of the (also uniform) rotation of a sensor, the system is a non-inertial one, i. e. it must be expected that inertial forces have an effect on the measurement. Up to now, there has, however, been no experimental evidence of a significant influence of these forces. Furthermore, motion is often not uniform, so that the quantities describing the system underlie time-dependent changes and dynamic phenomena can occur. Examples of these are start-up or decelerating processes which are necessary for any change in the motion status. If the torque variations occur slowly enough, the torque is a quasi-static one. But how slowly is “slowly enough”? This question cannot be answered by means of a single number because the transition towards dynamic effects and influences is blurred and depends on the respective situation. Furthermore, it is of significance how much accuracy is required for torque measurement – which requirements are placed on the measurement uncertainty. The more accurate one needs to be and the higher the resolution is, the more one will notice deviations between the non-accelerated and the accelerated rotational state.

4 Realization of static torque without motion

• Deadweight facilities

Deadweight facilities use a pivoted lever whose length is precisely known and at whose end the weight force of load masses (also called “weights”) in the gravitational field of the Earth are used for static force generation. In turn, this force is traced back to the quantities “mass”, m (with the base unit “kilogram”) and “local acceleration”, g (i. e. traced back to the quantities “length” and “time” with the base units “metre” and “second”). Stainless steels are approved as a suitable material for the masses. This procedure permits relative measurement uncertainties of 10^{-5} to be achieved when the effect of buoyancy in the air is taken into account. Also, time stability of the force is ensured. Only air pressure variations – which modify the air density – can, in extreme cases, become so significant that they must be taken into account [1]. The gravitational acceleration value which changes twice a day due to tidal forces is, however, negligible since its relative amplitude lies around 10^{-7} [2].

A non-negligible problem, however, is the question of the introduction of force into the lever arm. Thereby, thin metal foils are preferably used which, as very flexible elements, can help to minimize the influence of bending moments in the area of the force introduction [3]. Other variants, such as knife-edge bearing systems or rolling bearings, pose more problems there, especially with regard to their long-term stability. Elastic fixed joints – which are often strain-controlled, i. e. the bending of the joint is determined at the surface by means of strain gauges and these signals are used for control or adjustment purposes of the facility – have also provided good results [4].

Another important aspect of the lever is the length of its arm, whose time stability must be considered. Today, length measurements with the smallest uncertainties in the sub-nanometre range are possible. Such measurements on structures as complex as a lever within a measuring system are, however, considerably more complicated. Each screw fitting leads to distortions causing a change in length of up to a few micrometres. Furthermore, the materials usually expand when the temperature increases. Temperature variations of ± 1 K lead, in the case of steel, to length variations of approx. $\pm 16 \mu\text{m/m}$, which corresponds to a relative torque change of $\pm 1.6 \cdot 10^{-5}$. Therefore, for precision facilities, either the temperature is maintained constant at approx. ± 0.2 K or materials with a clearly lower coefficient of thermal expansion α must be used. In larger laboratory rooms, in spite of the air-conditioning, it is difficult to fulfil tem-

perature stability alone. Therefore, it seems more recommendable to combine both methods. The advantage is that sensors can be investigated – within certain limits – at modified temperatures without influencing the realized torque. Such a material with a low α is Superinvar, an alloy with a 50 to 100 times lower coefficient of thermal expansion compared to stainless steel or aluminium. The length of the lever arm can be determined in different ways: either by measurement by means of a coordinate-measuring machine or by comparison with a calibrated gauge block at the measuring facility itself.

“Force” and “lever arm” are now defined; the question as to how to realize “pure” torque, however, remains. For this purpose, it is helpful to understand how a bearing works. A body remains in a state of rest with regard to its base if the base compensates the weight force and other externally acting forces by corresponding reaction forces. The total counteracting force has thereby always the same value as that of the resulting force of the acting forces, but it has the opposite sense of direction. This works also in the case of a force couple: when the lever is supported, then the weight force which acts at the end of the lever must be compensated by the bearing. The difficulty thereby resides in the fact that the bearing must be realized in such a way that this causes no retroaction onto the generated torque. One can consider hydrostatic, aerostatic or magnetic bearings in which the influence on the transmitted torque is basically limited to friction influences thanks to a mechanical or magnetic decoupling between the mobile rotor and the immobile stator. An aerostatic bearing (air bearing) was chosen due to the – partially – very good experience gathered with this special type of bearing in numerous other fields.

Based on the fundamental remarks stated here, the metrologists’ task is now to detect and investigate further influence quantities. For this purpose, it is helpful to replace “force” in equation (1) by the quantities it is traced back to and to complement the other influence quantities $\Delta\bar{M}_i$ so that one can obtain the following compact representation for the generated torque on the basis of the densities – of air ρ_L and of the material of the load masses ρ_m – as well as with the local gravitational acceleration \bar{g}

$$\bar{M} = m \cdot \left(1 - \frac{\rho_L}{\rho_m} \right) \cdot \bar{r} \times \bar{g} + \sum_i \Delta\bar{M}_i. \quad (2)$$

In general, the investigations are carried out individually for each measuring system. Without going too much into detail, here is a list of some of the influencing quantities:

- remaining bending moments of the metal foils;
- remaining friction moment in the air bearing;
- influence of the pressurized air variations in the bearing;
- magnetic fields between the load masses;
- air streams between the load masses (Bernoulli effect);
- electrostatic forces between the load masses;
- mechanical by-passes.

By measuring or estimating the values of the input quantities which contribute to the resulting quantity and its uncertainties, one obtains an overall statement for the realized torque [5].

At PTB, torque is realized in a range from 1 mN · m (see Figure 1) to 20 kN · m in dead-weight facilities with horizontal measuring axis, whereby the smallest expanded relative measurement uncertainty ($k = 2$) lies at $2 \cdot 10^{-5}$. A schematic representation of this type of measuring system is shown in Figure 2.



Figure 1:
1-N · m torque standard machine with a measuring range from 1 mN · m to 1 N · m

• Force-measuring facilities

For higher torques – as must be measured, e. g., for turbines in power engineering or for drilling rods in oil production or gas extraction – the deadweight principle with air bearing reaches its limits – technically as well as financially. For this purpose, PTB has chosen a different way: the measuring system with the highest torque worldwide (two overlapping measuring ranges from $4 \text{ kN} \cdot \text{m}$ to $1.1 \text{ MN} \cdot \text{m}$) has a vertical measuring axis, i. e. the torque vector has a vertical orientation. The forces acting at the ends of a two-arm measuring lever are measured directly by means of calibrated force transducers. Correspondingly, the torque is generated via two motor units located on the driving lever (see Figures 3 and 4). Special sensors thereby allow the minimization of cross forces and bending moments for the adjustment of the force couple in order to obtain pure torque.

This approach has a certain number of advantages:

- the use of large masses is avoided;
- the force couple is generated and measured directly;
- no complex bearing systems are necessary, and
- the deadweight of the transducers and adaptation elements does not lead to an asymmetric bending strain but acts as an axial force.

Due to this design, the achievable measurement uncertainty is, of course, higher than with deadweight systems but it can be better than 0.1 % when using precision transducers and at best even lie in the range of a few 10^{-4} – which is often sufficient for this measuring range.

• Reference facilities

For many applications and calibrations, the time and effort spent on deadweight facilities is in no relation to the actual use. Thus, especially in the industrial sector, measuring devices with plug-in square drives are often used which have a considerable influence on the measurement result. Sometimes, also the resolution of the electronic display unit – if available at all – is low. Also scales which must be read out limit the number of digits available to express the measured value. In such cases, the utilisation of a measuring system in which a calibrated torque transducer (see section 8) is used as a standard is sufficient. The transducer thus becomes the bearer of the unit, i. e., the reference with which test objects are compared. This procedure is therefore called the “comparison method”.

By means of this measuring principle, a range from $0.01 \text{ N} \cdot \text{m}$ to $5 \text{ kN} \cdot \text{m}$ is covered at PTB, whereby the smallest expanded relative measurement uncertainties ($k = 2$) achieve $2 \cdot 10^{-4}$.

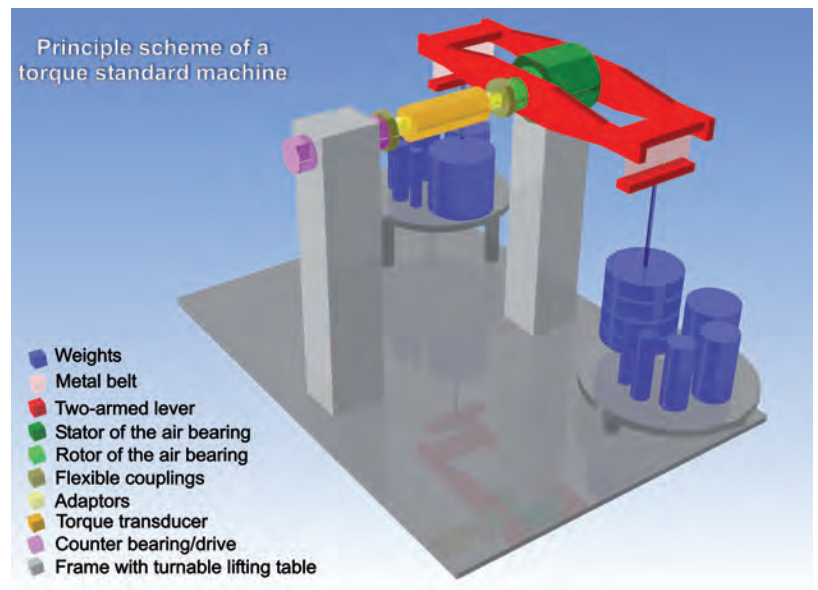

Figure 2:
Schematic representation of a torque standard machine with deadweights

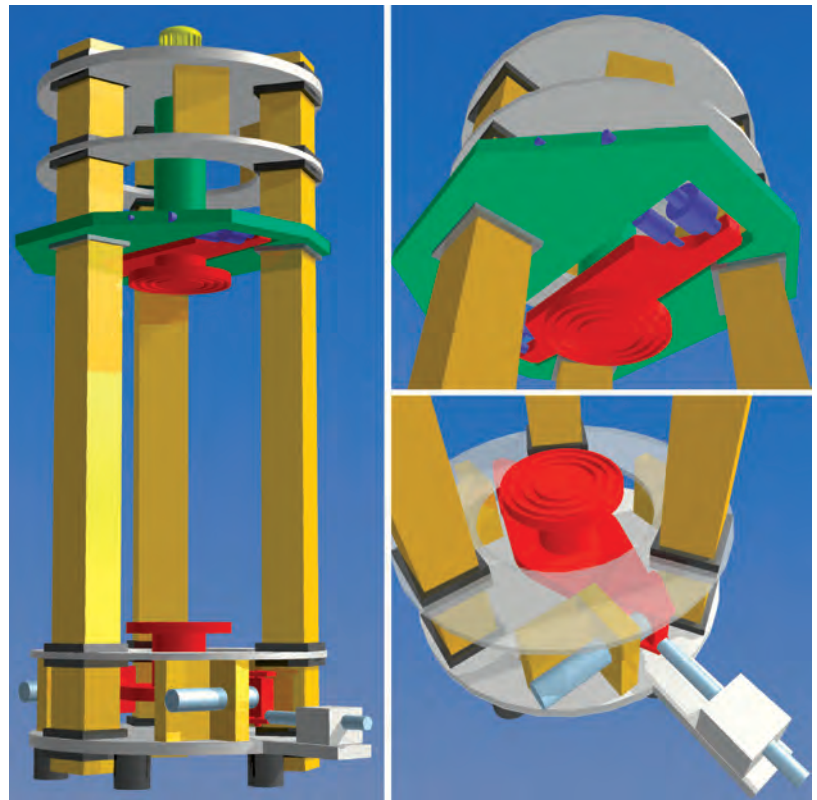

Figure 3:
Schematic overview of a force-measuring torque calibration facility (left), view of the measuring side (top right) and of the torque generating side (bottom right)



Figure 4:
1.1-MN · m torque
standard machine with
measuring ranges from
4 kN · m to 220 kN · m, as
well as from 20 kN · m to
1.1 MN · m

- **Torque wrench measuring systems**

The particularity of the moment of force as the superposition of force and torque becomes evident in the case of torque wrenches, whereby one can expect that the range to be realized extends, due to manual operating, from approx. 1 N · m to 3000 N · m. A pure torque is introduced into the torque wrench; the counteracting moment builds up via support on a lever which has been mounted especially for this purpose. The cross force which depends on the length of the lever arm thereby retroacts on the torque generation; it must therefore be ensured that this retroaction does not distort the generated torque. For this purpose, an interposed air bearing or a reference transducer which has been proven to be insensitive in this direction (preferably designed as a short flange in order to minimize the bending moments due to the cross force) are basically suitable.

The Working Group “Realization of Torque” operates three measuring systems with additional levers, in which torque wrenches are calibrated. These are generally torque transfer wrenches which are used for the calibration of torque wrench calibration facilities as bearers of the unit “moment of force” (for more information on this topic, please refer to section 8).

- **Servo screwdriver measuring systems**

In industry, screwing tools are used for torques from 1 kN · m to 150 kN · m which, until recently, could not be traceably calibrated. These de-

vices operate with mechanical gearing, hydraulic or pneumatic drives and, generally, very short, one-sided supports.

Investigations with regard to the determination of the measurement uncertainty of torque transducers at high superposed cross forces and bending moments have shown that the additional contribution to the measurement uncertainty budget due to superposed components could be reduced to less than 0.5 % of the measured value. This makes the calibration of servo screwdrivers possible. The measuring system having a measuring range of up to 150 kN · m and a one-sided lever arm length of max. 750 mm is shown in Figure 5.

- **Manually operated torque tools**

Such measuring devices are often small screwdrivers or dial gauges with integrated torque measurement. Their resolution and accuracy is generally low so that a traceable calibration is rather incumbent on a laboratory that has been accredited by the DKD (see 8).

5 Realization of static torque in the rotating case

One application of (quasi-)static torque in rotation, which has been investigated at PTB, is the calibration of ergometer test benches. These are used for the calibration of foot crank ergometers dedicated to medical purposes. Examinations at regular intervals are prescribed by the “Operating Regulation for Medical Products” for such devices.

They basically consist in the determination of the rotational power which results from the product of the simultaneously measured quantities torque and rotational speed (number of revolutions per minute). The measurement uncertainty requirements for static torque lie, in this case, at approx. 0.05 %, which can be achieved by using a high-quality torque transducer having been calibrated on a static deadweight facility. Due to various additional influences, the measurement uncertainty for the rotational power lies at best at 0.3 % (up to 1000 W at a maximum torque of 75 N · m and in the rotational-speed range from 10 min⁻¹ to 150 min⁻¹).

Until a few years ago, most ergometer test benches were still linked up directly to the PTB standard. This standard is presently still located at PTB’s site in Berlin Charlottenburg, but it will shortly be transferred to the Torque Working Group in Braunschweig. The link-up of ergometer test benches has recently been taken over by an accredited laboratory within the scope of the DKD, so that PTB’s contribution is now limited to special examinations of newly developed devices, calibrations in exceptional cases, as well as expertise on behalf of the DKD.



Figure 5:
Hydraulic servo screw-
driver up to 70 kN·m in a
calibration facility

In the past, individual experiments on the measurement of a constant torque under rotation were carried out at the torque laboratory whereby both the zero signal (amongst others at numbers of revolutions of up to 40,000 min⁻¹) and the characteristic value were investigated. The influences caused by rotational effects which were thereby detected are so negligible that they need not be taken into account in the case of the ergometers.

6 Realization of dynamic torque

In many applications, torque occurs as a dynamic, i. e. as a temporally more or less rapidly variable quantity. Research, especially in the field of dynamic force measurement, has shown that dynamics and the forces it involves can have a considerable influence on the measurement result. Resonance phenomena, amongst others, thereby play a role. For dynamic torque, there are presently preliminary investigations being carried out [6] and a first measuring facility exists [7]. A torque transducer to be calibrated is mounted into this facility between a rotational motor (rotational shaker) and a mass with a precisely known moment of inertia J . A torque $M(t)$ generated by the shaker and introduced into the transducer causes a rotary oscillation with the instantaneous angular acceleration $\ddot{\varphi}(t)$, whereby the mentioned quantities are linked via a relation which is similar to Newton's second law:

$$M(t) = J \cdot \ddot{\varphi}(t). \quad (3)$$

It is thereby presupposed that the moment of inertia J is constant – which, however, is not a fundamental condition. The angular acceleration is measured by means of interferometry, so that the torque directly derives from these two quantities.

Work in this field is still at the stage of research, so that calibrations are not yet being offered. It is, however, envisaged to introduce the

dynamic measurement of torque into metrological practice in the medium term.

7 Comparisons and dissemination of the unit; standardization

PTB's task not only consists in realizing the units, but also in verifying the procedures and results by means of comparisons with peer institutes and in ensuring the dissemination to subordinate bodies.

For comparison measurements, special measuring sequences and procedures are often developed which are adapted to the needs of one specific comparison. These play an important role in ensuring worldwide comparability of measurements and their results, especially for international comparisons such as key comparisons.

The dissemination of the unit is specially regulated at the level of the DKD through the accreditation of laboratories which are directly or indirectly linked up with PTB. But also other – partly foreign – clients have their measuring instruments calibrated at PTB. This is generally done according to standardized procedures. PTB's Working Group "Realization of Torque" has often been intensely involved in developing and elaborating these procedures and has, on various occasions, been in charge of such tasks. Due to the "two faces of torque", it is necessary to deal with the case of torque wrenches – or rather their calibration facilities – separately (DKD-R 3-7 and 3-8 as well as DIN/EN/ISO 6789).

Important standards whose scope of application and particularities are summarized in Table 1.

The parameters to be examined for the calibration of a measuring instrument are, for example, the repeatability and reproducibility. These state how much the output signal of a sensor is subject to variations when a measurement is repeated in unaltered (repeatability) or in altered mounting position (reproducibility).

Table 1:
Important standards with regard to the calibration of torque meters

Standard	Scope of application	Remarks	Current issue
DIN 51309 [8]	Torque transducers	Clockwise/anti-clockwise torque	2005-12
DKD-R 3-5 [9]	Torque transducers	Alternating torque	1998-12
DKD-R 3-7 [10]	Indicating torque wrenches	Torque transfer wrench Higher-precision torque wrenches with indication (cf. DIN/EN/ISO 6789)	2003-10
DKD-R 3-8 [11]	Calibration facilities for torque wrenches	Calibration of torque wrench calibration facilities	2003-10
DIN/EN/ISO 6789	Hand torque tools	Screwdrivers and wrenches- Hand torque tools	2003-10
VDI/VDE 2646	Torque meters	Minimum requirements on calibrations, initial calibrations	2006-02
EA 10/14	Measuring instruments for static torques	European Standard, in revision as EURAMET Guideline [12, 13]	2007-07

Furthermore, hysteresis plays a role which is expressed by the fact that one obtains a slightly different signal when one adjusts the same torque for increasing or decreasing amplitudes. In the case of torque wrenches, there is, in addition, a dependence on the lever length because the cross force belonging to a given torque decreases when the length of the lever increases (lever principle). Further parameters are the non-linearity or the time-dependent change of the display at a constant load – the so-called “creep”. It is only the calibration of a measuring instrument that can prove whether it can meet certain requirements – or not.

8 Metrological infrastructure and Deutscher Kalibrierdienst (DKD)

As mentioned above, the Working Group “Realization of Torque” supports the metrological infrastructure, especially by ensuring the traceability to standards, but also through consultation and collaboration in the drafting of guidelines. The Working Group is represented within Board 10 “Torque” of the Deutscher Kalibrierdienst (DKD - German Accreditation Service) by an advisor. The bi-annual meetings are carried out jointly. Amongst other things, interlaboratory comparisons are regularly organized and supported. Furthermore, the DKD commissions experts from the Working Group with the assessment of laboratories within the scope of accreditations according to DIN/EN/ISO 17025. Also, within the last decade, numerous national institutes in other countries have purchased or

developed and set up measuring facilities of their own so that, today, measurements can be carried out at an international scale which help secure worldwide comparability in order to ensure reliable measurements – in whatever country they may have been carried out.

Literature

- [1] *Davis R. S.*: Equation for the Determination of the Density of Moist Air (1981/91), *Metrologia* **29** (1992), pp. 67–70
- [2] *Torge, W.*: Gravimetry, de Gruyter, Berlin 1989
- [3] *Röske, D.*: Realization of the Unit of Torque – Determination of the Force-Acting Line Position in Thin Metal Belts, Proc. of the 15th International Conference of IMEKO TC3 “Accuracy, Assurance in Force, Torque and Mass Measurements”, Madrid (Spain), Oct. 7–11, 1996, pp. 261–264
- [4] *Gassmann, H.; Allgeier, T., Kolwinski, U.*: A New Design of Primary Torque Standard Machines, Proc. of the XVI IMEKO World Congress, Vienna (Austria), Sept. 25–28, 2000, vol. III, pp. 63–73
- [5] *Peschel, D.; Röske, D.*: Messunsicherheiten bei der Drehmomentmessung, *Technisches Messen*, **72** (2005), 5, pp. 308–324
- [6] *Wedmann, A.*: Experimentelle Bestimmung des Rotormassenträgheitsmomentes einer Normalmesseinrichtung zur Kalibrierung mit dynamischem Drehmoment, Diplomarbeit, Fachhochschule Lübeck, 2005
- [7] *Bruns, Th.; Kobusch, M.*: Rückführung dynamischer Kraft- und Drehmomentmessungen

- mithilfe von Laser-Doppler-Interferometrie, *Technisches Messen* 72 (2005), 3, pp. 130–135
- [8] DIN 51309: Kalibrierung von Drehmomentmessgeräten für statische Drehmomente. Hrsg. vom Deutschen Institut für Normung e. V., Edition of December 2005
- [9] DKD-R 3-5: Kalibrierung von Drehmomentmessgeräten für statische Wechseldrehmomente. Hrsg. vom Deutschen Kalibrierdienst. Edition of December 1998, www.dkd.eu/dokumente/Richtlinien/dkd_r_3_5.pdf [Accessed: 18-03-2008]
- [10] DKD-R 3-7: Statische Kalibrierung von anzeigenden Drehmomentschlüsseln. Hrsg. vom Deutschen Kalibrierdienst. Edition of October 2003, www.dkd.eu/dokumente/Richtlinien/dkd_r_3_7.pdf [Accessed: 18-03-2008]
- [11] DKD-R 3-8: Statische Kalibrierung von Kalibriereinrichtungen für Drehmoment-schraubwerkzeuge. Hrsg. vom Deutschen Kalibrierdienst. Edition of October 2003, www.dkd.eu/dokumente/Richtlinien/dkd_r_3_8.pdf [Zugriff am: 18.03.2008]
- [12] EA-10/14: EA Guidelines on the Calibration of Static Torque Measuring Devices. June 2000, www.euromet.org/docs/calguides/EA-10-14.pdf [Accessed: 18-03-2008]
- [13] EURAMET/cg-14/v.01: Guidelines on the Calibration of Static Torque Measuring Devices. July 2007, URL: www.euromet.org/euramet/Calguides/EURAMET-cg-14.01_Static_Torque_Measuring_Devices.pdf [Accessed: 18-03-2008]

Multi-component Measurements of the Mechanical Quantities *Force and Moment*

Dirk Röske*

1 Terms

The quantities *force* F and *moment* M are vectors and as such are determined not only by a numerical value (scalar) and a unit, but also always by a direction in space or in the plane and a corresponding sense of direction, for example tension or compression force, clockwise or anti-clockwise torque. To describe a vector, one can draw on its magnitude and, for instance, via suitably defined angles, on its direction with regard to a given coordinate system. Another approach would be to separate the vector into individual elements, so-called components, which contain the “proportion” of the vector along the coordinate axes. In the case of movements, one speaks, for instance, of longitudinal and transverse motion with regard to a defined direction, in the case of forces, of axial and transverse force. The separation of the vector is carried out by determining its projections on the coordinate axes. The values of the components thus found are scalars. As a group they clearly describe the vector, i. e., in the plane, two values, and in space, three are needed for the components of the vector.

From a theoretical viewpoint, the various components are of equal significance, which is why the names of the coordinate axes x , y and z are used, as a rule, for their denotation. One speaks then of the x -component of force (F_x) and so forth. Often, however, the case occurs where one of the components is more important, perhaps because it influences the measurement result more strongly than the other two do. Possibly it is also emphasised by the geometrical shape of the body loaded with it, for example by its axis of symmetry. In this case one speaks of the force as the axial force component (or short form: axial force), and the moment as the torque. Both generally determine the z -direction.

The quantities force and torque dealt with in the previous contributions are to be understood as components defined in such a manner whereby it is assumed that the magnitudes of the respective other two components – the transversal force

and bending moment components, which taken together in this case are also designated as disturbing components – are zero in the ideal case.

2 Problems in multi-component measurement

In the case of multi-component measurement, all components are treated uniformly – in this sense there are no disturbing components. However, forces and moments cannot be directly compared with one another, as they have different dimensions which differ by a length dimension. As a criterion of comparison, one can, however, draw on the mechanical tensions caused in a body by the load with the quantity and/or on the expansions which are connected with them and which are required for the measurement with the aid of strain gauges.

Thus, the most diverse cases are possible:

- all components have approximately equally large magnitudes (application: robots, manipulators, crash test dummies, wheel load sensors)
- a great axial force in combination with a (relatively) small torque (pretensioning force of a screw which is tightened with the torque)
- a greater torque combined with a comparably smaller axial force (measurement for bores, wind power turbines).

From this by far incomplete list one can conclude that there is an abundance of combinations possible which cannot all be covered by a standard measuring method.

To complicate matters further, there is a close relationship between the quantities. Thus, for example, a transversal force acting at a given distance from the reference point always calls up at least one (spatially dependent) moment component. A torque not ideally realized as force couple is linked with additional transversal forces and (again spatially dependent) bending moments. From the theoretical viewpoint, one can indeed describe a load condition in a specified point by exactly six values – the three force and the three moment components. For other

* Dr. Dirk Röske,
Head of the Working
Group “Realization of
Torque”,
e-mail:
dirk.roeske@ptb.de

points, other values generally result, such that one must actually speak of a vector field. Thus it must be clarified as to which point the result is to be referred to, if one does not or cannot specify whole tables or functions. The problem can often be narrowed down when it is known at which position the forces and moments are in demand and at which they are measured. For a wheel-load sensor, the contact force at the contact surface between wheel and road, for example, as well as the torque transmitted there, and also the transversal force in the case of cornering, could play a role. In the case of the screw, the head as well as the shaft friction moment and/or the pretensioning force are of interest in order to optimise screw connections.

Furthermore, during the measurement of forces and moments, additional effects occur which have to be taken into account. Thus, the output signal of a measuring bridge is not absolutely linear, but rather shows dependencies with a higher degree on the quantity to be measured. Furthermore, there are time-dependent and direction-dependent influences in the case of a given value of the measurand. For the latter, the readout is different when the value is set on the basis of increasing or decreasing values. A further considerable influence is the crosstalk, which manifests itself in more or less large signals that are received on all measuring channels when in fact only one component is applied.

This multitude of parameters and interactions leads to a complexity of the problem, which has certainly contributed to the fact that multi-component measurement has not yet attained the developmental stage of (axial) force and torque.

3 Solutions for the realization of multi-component situations

The standard approach to the realization of multi-component force and moment loads consists in the generation of a certain ensemble of components for a given point in space. In an alternative realization, this means that a force and a moment vector are realized in this point whereby both vectors are determined by their magnitude, direction and sense of direction.

Due to the above-described diversity of the multi-component situations, there are also various approaches for their realization. Very generally, they can be assigned to one of two principles, both of which have advantages and disadvantages.

In the case of the serial systems, the attempt is made to decouple the components as well as possible. They are supposed to then be able to be generated and superposed as single components. Examples of this are often equipped with orthogonal drive and measuring elements which are directed along the axes of a defined coordinate system.

In the case of the parallel systems (parallel kinematics) the attempt is not made to divide the components, but rather the superposition of the components is taken into account already at their generation. However in this case one must describe the system via its geometrical arrangement or follow another path of traceability (position and angle measurement).

Parallel kinematics are often employed in the case of robots, driving and flight simulators or of machine tools. They are often more compact and easier to realize than serial systems and thus offer improved dynamics. In the Working Group "Realization of Torque" of the PTB, the attempt was made for the first time to use parallel kinematics formed as a hexapod (Greek: "six-footed") for metrological purposes [1, 2]. Since it was a matter here not only of measuring the position, but rather the forces and moments, the corresponding sensors had to be integrated.

4 Design principle of the hexapodal equipment

A basic principle of the multi-component reference measuring machine (MK-RME, see Figure 1 as schematic representation and the photo in Figure 2) developed at the PTB consists in a spatial separation of drive and measurement. This means that the machine contains two mirror-symmetrically set up hexapods (the pods are represented in red in the figure), one in the upper part with six motors (yellow) for generating the load and one in the lower part for the measurement of the created forces and moments with the aid of calibrated force transducers (grey). The point of reference is freely selectable thereby. In general, it is determined by the transducer to be calibrated and is incorporated into the software, which carries out the necessary calculations.

The upper hexapod can be vertically shifted as a whole in order to enable the installation of a transducer and/or the adjustment to different

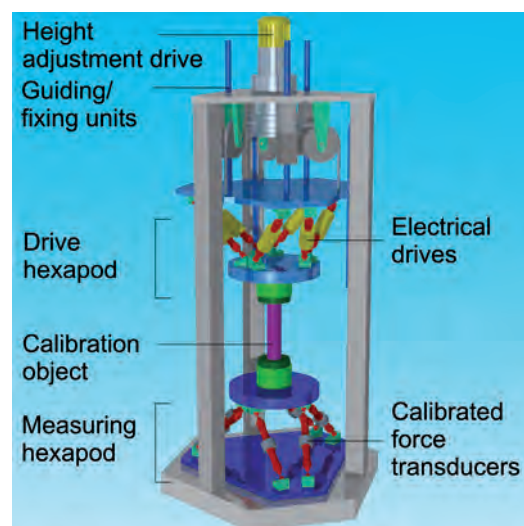

Figure 1:
Principal figure of the multi-component reference measuring machine.



Figure 2:
Multi-component refer-
ence measuring machine
with a force vector mag-
nitude of maximum 10 kN
and a moment vector
magnitude of maximum
1 kN·m.

transducer lengths. This movement is carried out with the aid of the motor mounted in an overhead center position, which vertically traverses the hexapod drive units via cables, reverse rollers and vertical guide rods. Locking is then carried out via the guide rods.

5 Theoretical fundamentals and practical implementation of the hexapod

From a theoretical viewpoint, six linearly independent model input parameters are needed for six unknown quantities – thus, for example, the three respective components for force and moment. In the case of the system presented here, these are the signals of the force transducers in the measurement pods. From them, it is possible to determine the forces acting in the measurement pods and, with the aid of a linear system of equations which contains the geometry of the arrangement, the unknown force and moment components for a given point.

The essential principle of the hexapod is that the signals of all six force transducers are measured simultaneously and that the acting components can be calculated at any time – likewise for the elongation of the driving pods. Due to the direct coupling, for a movement to be made

it is almost always necessary to move all drives simultaneously. Parallel kinematics owe their name to this parallel mode of operation.

In addition to the calibration of the force transducers, it is naturally necessary to also measure the spatial arrangement of the hexapods. The measuring hexapod consists of an angular base plate and a round cover plate as well as six pods connecting both plates. The latter feature at their ends tapered elastic fixed bearings. These are necessary to ensure that the force transducers represented in grey (see Figure 1) will not experience any other loads than the axial force for which they are calibrated. Due to the distortion of the hexapod, additional transversal forces, namely, as well as torques and bending moments can be created which could distort the signals of the force transducers.

On the other hand, these bearing points have another important function: They can be drawn on as reference points for the determination of the geometric arrangement. The measurement of the pod lengths between the bearing points and their mutual position in space was carried out on a coordinate measuring machine for these points.

The results of these measurements and the calibration data of the force transducers are also incorporated into the software which calculates the required quantities, from the input data.

6 First measurements and prospects

The multi-component reference measuring machine has been designed for continuous, quasi-static measurements; no dynamic loads are intended.

In first measurements, in addition to a torque transducer with bending moment bridges, a sensor for structural monitoring [3], two multi-component transducers [4] as well as a novel force vector sensor [5] were tested. The results agree sufficiently well with results from other measuring systems. Nevertheless, there is still a need for optimizing, particularly with regard to the time response and the software for operating the system.

The measuring machine presented here covers only a small portion of the broad field of multi-component measurements. This applies both to the measuring ranges as well as the relation of the magnitudes of both the quantities force and moment. If one considers the other cases mentioned in section 2, that, for instance, a great axial force occurs in combination with a small torque (pretensioning force for screws and screwing torque), then new solutions must be sought for it. For this purpose, for the force and/or the torque measuring machines (see the corresponding articles in this issue), supplementary devices could be developed and constructed

which enable the generation of further components within the machines. Such a supplementary device is already being produced for the 100 kN force standard measuring system [5].

In all likelihood, for special multi-component measuring tasks special multi-component measuring systems will be needed. That means that there will probably be no all-purpose multi-component system which can fulfil the requirements of diverse measuring tasks at the same consistent level. Furthermore, the national and international standardization of the measuring method in the field of multi-component measurement has not yet been regulated. There is some need for action here.

Literature

- [1] *Röske, D.; Peschel, D.; Adolf, K.*: The generation and measurement of arbitrarily directed forces and moments: the project of a multi-component calibration device based on a hexapod structure, 17th IMEKO TC3 conference (Force, Mass, Torque and Pressure Measurements at Present and in the Future), September 17–21, 2001, Istanbul, Turkey, on CD-ROM
- [2] *Röske, D.*: Metrological characterization of a hexapod for a multi-component calibration device, XVII IMEKO World Congress (Metrology in the 3rd millennium), June 22–27, 2003, Dubrovnik, Croatia, on CD-ROM
- [3] *Tegtmeier, F. L.*: Mehrkomponenten-Dehnungsaufnehmer für das Monitoring von Bauwerken, Braunschweig, Techn. Univ., Dissertation, 2005, 184 S.
- [4] *Park, Y.-K.; Kumme, R.; Kang, D.-I.*: Dynamic evaluation of column-type multi-component force transducers, XVIII IMEKO World Congress (Metrology for a Sustainable Development), Rio de Janeiro, Brazil, 17–22 September, 2006, on CD-ROM
- [5] *Lietz, S.; Tegtmeier, F. L.; Kumme, R.; Röske, D.; Kolwinski, U.; Zöller, K.*: A new six-component force vector sensor – first investigations; IMEKO TC3 & TC16 & TC22 International Conference, 27th November – 1st December, 2007, Merida, Mexico, on CD-ROM

Pressure Measurement from Kilo- to Gigapascal

Wladimir Sabuga*

1 Introduction

“Pressure” is not only one of the most important parameters of state, it ranks among the most frequently measured physical quantities in many fields of our daily life and among the essential process parameters in many industrial procedures. Heating engineering, air conditioning, power station technology, bio- and chemical process technology, gas and energy supply, the automobile industry, mechanical engineering, apparatus and plant engineering, aviation, transport, medicine, defence and scientific research are only some of the great number of fields of application where pressure measurements are indispensable. In Germany alone, the number of newly manufactured and installed pressure measuring devices amounts to several million per year. Especially pressure measuring devices which are used for the measurement tasks defined in the Verification Act (tyre pressure measurement on vehicles, pressure measurement during the production of pharmaceutical products, commercial or official transactions etc.) must be subjected to type examination and approved for use in the area subject to legal control.

2 Definitions

The physical quantity pressure p is defined as the quotient from the perpendicular force F_N which – in a liquid or gaseous medium – uniformly acts on an area A [1]:

$$p = \frac{F_N}{A} \quad (1)$$

The unit of the pressure in the International System of Units (SI) is the pascal (Pa): $1 \text{ Pa} = 1 \text{ N/m}^2 = 1 \text{ m}^{-1} \text{ kg s}^{-2}$ [2]. The legal basis for metrology at the European level is the Council Directive for Adaptation of the Legal Regulations of the Member States on Units in Metrology. For Germany, the “law of units of measurement” (Units Act) defines, in addition to the pascal, the bar, $1 \text{ bar} = 10^5 \text{ Pa}$, for pressure measurements, and the millimetre of mercury (mmHg), $1 \text{ mmHg} \approx 133.322 \text{ Pa}$, for the measurement of blood pressure and the pressures of other body fluids. The pressure

units previously used, such as kilopond divided by square centimetre (kp/cm^2), technical atmosphere (at), physical atmosphere (atm), torr (torr), conventional metre water column (mWS) must no longer be used and are converted into the SI unit “pascal” in accordance with the following relations:

$$1 \text{ kp/cm}^2 = 1 \text{ at} = 98\,066.5 \text{ Pa},$$

$$1 \text{ atm} = 101\,325 \text{ Pa},$$

$$1 \text{ Torr} = 101\,325/760 \text{ Pa} \approx 133.322 \text{ Pa},$$

$$1 \text{ mWS} = 9806.65 \text{ Pa (DIN 1314)}.$$

Depending on the reference pressure, a distinction is made between three pressure types. The absolute pressure, p_{abs} , is the pressure compared to zero pressure in the empty space. The gauge or relative pressure, p_g , is the difference between an absolute pressure p_{abs} and the respective (absolute) atmospheric pressure, p_{amb} : $p_g = p_{\text{abs}} - p_{\text{amb}}$. The gauge pressure assumes positive values when the absolute pressure is larger than the atmospheric pressure; it assumes negative values when the absolute pressure is smaller than the atmospheric pressure. The differential pressure is the difference Δp between two pressures p_1 and p_2 , $\Delta p = p_1 - p_2$, or $p_{1/2}$ if it is the measurand itself.

3 Pressure ranges

The range of absolute pressures below the atmospheric pressure, whose lowest value on the Earth’s surface amounts to approx. 300 hPa, belongs to the vacuum range to which the following contribution of Jousten [3] is dedicated. The natural pressures occurring on Earth, from the troposphere, at an altitude of approx. 55 km, to the Earth’s core, cover the large range from approx. 25 Pa to 364 GPa (Figure 1).

The maximum pressure “accessible” to man naturally prevails at the deepest place in the oceans, in Witjastief 1 in the Mariana Trench (depth: 11 034 m), and amounts to 110 MPa. The maximum pressure generated in solids in the laboratory approximates that in the Earth’s centre. For liquids, the upper limit of artificial pressures lies at 20 GPa [1]. The maximum pressure applications with industrial importance comprise diamond and hard metal synthesis, for

* Dr. Wladimir Sabuga,
Head of the Working
Group „Pressure“,
e-mail:
wladimir.sabuga@
ptb.de

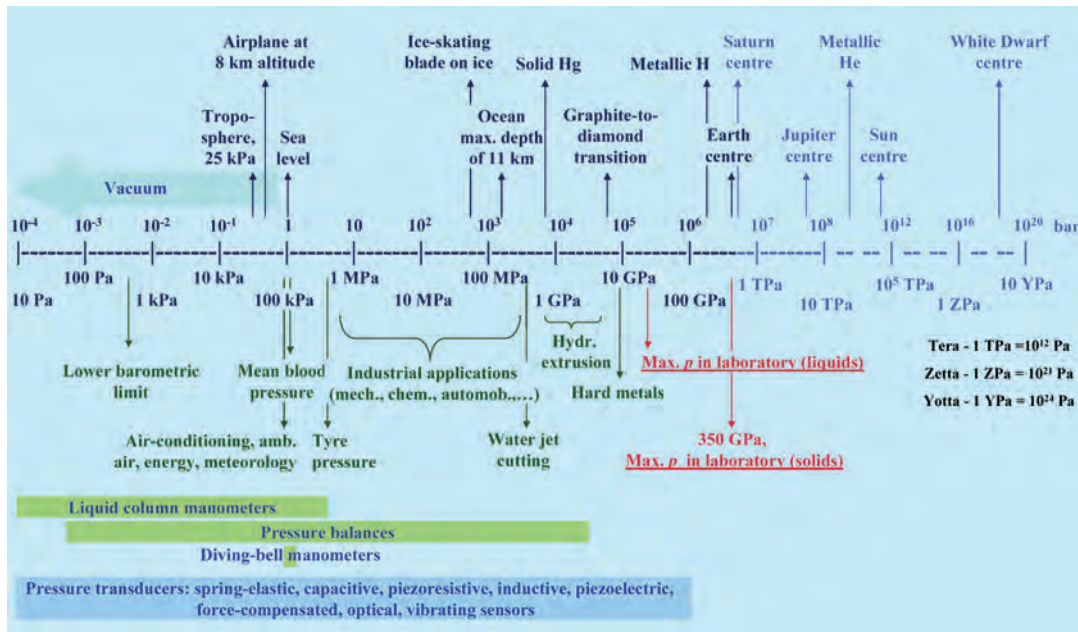

Figure 1: Pressures on the Earth and on other planets, in the laboratory and in industrial applications. Fundamental and directly measuring pressure devices and procedures

which pressures between 4 GPa and 10 GPa are required. The upper limit of the technical pressure scale for which reliable traceability of the pressure measurements to the SI base units is guaranteed, lies at 1.5 GPa. The most important technological processes, for which pressures up to 1.5 GPa are required and which must be measurable with a comparatively high accuracy, comprise hydraulic extrusion and autofrettage. The last-mentioned procedure allows the service life of the components, which are exposed to high pressure in operation (such as high-pressure pipes, high-pressure pumps and fittings, vehicle diesel injection facilities and firearms) to be increased many times. The predominant part of the industrial applications – which comprise the most diverse pneumatic and hydraulic facilities, processes in the chemical industry and the automobile industry, material processing with water jet facilities, gas supply and many others – is performed in the pressure range between 1 MPa and 300 MPa [4]. A new procedure for the sterilization of food without thermal treatment, in which the food is exposed for a short time to a pressure of (0.7 to 1) GPa, offers many advantages and is already routinely used in some industrialized countries. Tyre and blood pressure measurements in the range from approx. 10 kPa to 500 kPa rank among the most frequently performed gauge pressure measurements with which the citizen is directly confronted. Small gauge pressures in the range of approx. ± 1 kPa are increasingly gaining in importance in connection with indoor air-conditioning and ventilation, clean-room technologies and energy generation. In meteorology (weather forecasting) and aviation (barometric altimetry), absolute pressures of approx. 100 kPa and below must be measured with a relatively high accuracy.

4 Pressure measuring methods

A distinction is made between direct and indirect pressure measurement methods [4]. Direct pressure measuring devices determine the amount of the pressure to be measured directly from the basis relation (1), or from

$$p = h \cdot \rho_F \cdot g, \quad (2)$$

whereby the latter represents the hydrostatic pressure of a liquid column, h being the height of the liquid column, ρ_F the density of the liquid and g the acceleration due to gravity.

Measuring devices which work in accordance with principle (2) are liquid column manometers, in which h is measured and p determined from it. The liquid column manometers comprise the U-tube manometer, the inclined-tube manometer and the float-type manometer in which the height of the liquid column is measured in different ways. Liquid column manometers are used almost exclusively for pressure measurements in gases. Depending on whether atmospheric pressure or zero pressure prevails in the reference level of the liquid column manometer, the device is used to measure gauge pressure or absolute pressure. Liquid column manometers can also be used for differential pressure measurements, e.g. measurements of small pressure differences at a high static pressure. The measurement range of liquid column manometers is usually limited to 1 Pa to 300 kPa (Figure 1). The smallest relative measurement uncertainty achievable may lie at a few 10^{-6} .

Pressure measuring devices which work in accordance with relation (1) are piston manometers, also called piston gauges or pressure balances, and pressure balances with manometric liquids.

In a piston manometer, the pressure acts on the cross-sectional area A of the piston and causes a force F_N . In the case of simple piston pressure meters for industrial applications, the piston is sealed and the force acting on the piston is compensated by a spring. The occurring spring displacement is a measure of the pressure. Due to the friction between the sealing and the piston, the accuracy of such piston pressure meters is not better than 1 %. Of greater importance are piston manometers with an unsealed piston which are used as pressure standards in measurement workshops and laboratories. In such piston manometers, a small gap between the piston and the pressure cylinder allows the free, frictionless movement of the piston in the cylinder. Mechanical contact between the piston and the cylinder is ruled out by a piston rotation (piston gauge), a special form of the piston-cylinder gap or by a mechanical support with the aid of which the piston is centred in the cylinder hole. The force of the pressure acting on the piston is compensated with weights applied to the piston or with the aid of an electronic weighing instrument. This force, divided by the effective area of the piston-cylinder unit, furnishes the measurement pressure. Commercial piston manometers allow pressures in gases from approx. 30 Pa to 100 MPa to be measured (in liquids up to 1.4 GPa) (Figure 1). Piston manometers are suited to measure absolute pressures, gauge pressures and differential pressures. The smallest relative uncertainties of the pressures measured with piston manometers lie between 10^{-6} and 10^{-5} .

In the case of the pressure balances with manometric liquids, the most important design of which is the diving-bell manometer, the manometric liquid has the task of separating the spaces with different pressures from each other. The measurement pressure acts on a defined area, e.g. the area of the internal cross-section of the bell immersed into the manometric liquid, and is compensated with a weight or measured with the aid of a dynamometer. The density of the manometric liquid has no influence on the measurement result. Due to the large cross-section, diving-bell manometers are especially suited for the precise measurement of small gauge pressures in the range $[-4; +4]$ kPa. The smallest measurement uncertainty achievable lies at $0.02 \text{ Pa} + 10^{-5} p_c$.

Devices which measure pressure indirectly are pressure meters which use the effect of a pressure on specially shaped bodies or on substances for pressure determination. Such effects are, for example, the elastic change in shape of hollow bodies or plates in spring-elastic manometers which – due to their simple handling, robustness and cost-effective manufacture – rank

among the most important pressure meters for many industrial processes. With the aid of a motion work, the elastic deformation of the measuring element is converted into a rotational angle of a pointer so that the measurement pressure can be read directly on a correspondingly subdivided scale. In many cases, the pointer movement is converted into an electrical or pneumatic, analog or digital signal so that the pressure meter can be used for automatic pressure determination or for process control. The smallest relative measurement uncertainty achievable of spring-elastic manometers has an order of magnitude of 10^{-3} .

In electric pressure metrology, the pressure is converted into an electrically measurable quantity. The elastic deformation of a hollow body caused by pressure is, for example, determined as the change of its electric resistance with the aid of strain gauges applied on it. Using different strain gauges and pressure body geometries, pressure sensors can be constructed for the pressure range from approx. 100 kPa to 1.5 GPa. In the case of capacitive pressure sensors, the deflection of a diaphragm, which serves as one of the capacitor plates and is subject to the pressure, leads to a capacity change to be measured. Such pressure sensors are particularly well suited for the measurement of small pressures or pressure differences from 1 Pa to 5 MPa. In the case of piezo-electric sensors, the pressure is converted into a mechanical force by means of a diaphragm and transmitted to piezo-electric crystals. The generated electrical surface charge is proportional to the load and leads to a measurable electric voltage. As the charges are discharged over the finite insulation resistors, piezo-electric sensors are mainly suitable for the measurement of dynamic pressures. Another important class of pressure sensors is based on the change of the resonance frequency of oscillating bodies, e.g. of quartz crystals, when these are loaded by pressure. This frequency change can be measured very exactly with a frequency counter. The resonance frequency pressure sensors are used in the pressure range from 1 kPa to 300 MPa and are characterized by a very good stability and resolution between 10^{-6} and 10^{-5} . When maximum pressures above the technical pressure scale are measured ($p > 1.5 \text{ GPa}$), resistance manometers and optical manometers are used [1, 4]. Resistance manometers measure the resistance change of a wire made of special alloys (e.g. manganin) wound up on a coil when it is hydrostatically pressurized. The optical pressure measuring principle is, for example, used in ruby sensors, in which a displacement of the fluorescence lines of ruby caused by the pressure load is measured. Ruby sensors allow pressures of more than 100 GPa to be measured.

5 Traceability to the SI units

Traceability of the pressure unit to the SI base units “kilogram”, “metre” and “second” is realized with the aid of primary liquid column manometers and pressure balances, using the relations (1) and (2) (Figure 2) [4, 5].

Due to the stability of its density, mercury is normally the liquid used in liquid column manometers [6]. The local acceleration due to gravity can be determined with a precision better than $5 \cdot 10^{-7}g$. The combined uncertainty of the pressure mainly depends on the uncertainty of the column height and the mean density of the mercury. The latter is strongly influenced by the temperature distribution along the column. For measurement of the column height, optical interferometry, capacitive determination of the menisci and ultrasound duration methods are used. The smallest relative measurement uncertainties of a few 10^{-6} are obtained close to atmospheric pressure. At higher pressures, the accuracy of the pressure measurement is increasingly influenced by the temperature inhomogeneity along the mercury column. In the case of smaller pressures, i. e. smaller columns, the accuracy of the pressure measurement decreases due to the increased relative uncertainty of the column height measurement.

For primary pressure balances, traceability to the SI base units is realized by determination of the local acceleration due to gravity, of the mass of the piston with the weights and of the effective area (A_0) of the piston-cylinder system. The two first quantities contribute only between 10^{-7} and 10^{-6} to the relative measurement uncertainty of the pressure. The effective area is decisive for the accuracy of the pressure measurement and is determined from the dimensional properties of the piston and the cylinder bore [7]. For this purpose, diameters are measured at several places, and roundness and straightness deviations are measured along the circular and generatrix lines both on the piston and on the cylinder bore. By combining the roundness and straightness data with the diameters, 3-dimensional data sets are established for the piston and the cylinder [8]. With the aid of this dimensional information, the flow in the piston-cylinder gap is modelled and the force acting on the piston is calculated as a function of the pressure under the piston. The relation of this force to the pressure furnishes the effective area. State-of-the-art devices for dimensional measurement allow the radii of pistons and cylinders to be determined with an uncertainty between 30 nm and 40 nm. In the case of nominal piston-cylinder sections of 5 cm^2 to 20 cm^2 , which can be manufactured with today's technologies (Figure 3), relative uncertainties of $(4 \text{ to } 6) \cdot 10^{-6}$ are obtained for the effective area.

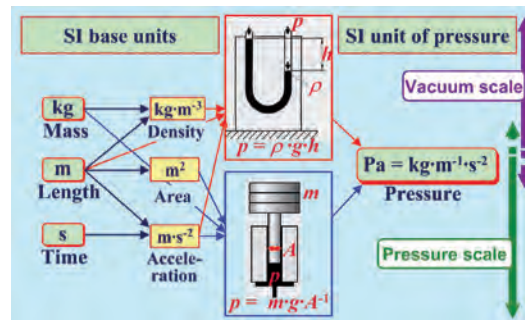

Figure 2:

Traceability of the pressure unit to the SI base units with the aid of liquid column manometers and pressure balances



Figure 3:

Piston-cylinder assembly with the nominal cross-sectional area 10 cm^2 for the primary realization of the pressure scale in gases in the range from 50 kPa to 1 MPa

Correspondingly small uncertainties of the pressure can be achieved with primary piston-cylinder systems in the range from approx. 100 kPa to 2 MPa. The downward extension of the pressure scale is realized with the aid of force-compensated, non-rotating piston manometers, capacitive membrane-type vacuum meters, static and continuous expansion procedures [3]. The upward extension of the pressure scale is achieved by the use of piston-cylinder systems with smaller A_0 . As the relative uncertainty of the dimensional characterization increases with a decreasing cross-section, A_0 of smaller piston-cylinder systems intended for higher pressures is no longer determined dimensionally, but from pressure comparison measurements against larger systems. With increasing pressure, the relative uncertainty increases approximately proportionally to the pressure, as the effective area of the piston-cylinder system changes due to the elastic deformation caused by the pressure. In the first approximation, the pressure-dependent cross-sectional area (A_p) can be described with the following equation:

$$A_p = A_0(1 + \lambda p), \quad (3)$$

with λ being the pressure distortion coefficient of the piston-cylinder assembly. In the case of the freely deformable high-pressure assemblies of tungsten carbide, λ lies between $7 \cdot 10^{-8} \text{ MPa}^{-1}$ and $8 \cdot 10^{-7} \text{ MPa}^{-1}$ and becomes – in the case of pressures above 50 MPa – the most important uncertainty source. For its more exact determination, the elastic constants of the materials of the piston-cylinder assemblies are measured and

then their elastic deformation is calculated with the aid of the finite element method [9]. Figure 4 shows the PTB standard twin pressure balance, with the aid of which the pressure scale in liquids is realized in the range from 0.5 MPa to 1 GPa.

This pressure balance is provided with a total mass of 500 kg and allows – with the aid of dimensionally measured 5 cm² piston-cylinder assemblies – pressures between 0.5 MPa and 10 MPa to be traced back directly to the SI base units [10]. By the installation of piston-cylinder assemblies with nominal cross-sectional areas of 84 mm², 30 mm², 8.4 mm² and 5 mm², the pres-



Figure 4:
Standard pressure balance for the realization of the pressure scale in liquids in the range from 0.5 MPa to 1 GPa.

sure scale is extended up to the maximum pressure of 1 GPa [11] which can be measured with a relative uncertainty of $1.3 \cdot 10^{-4}$. In the range from 1 GPa up to the pressure of 1.4 GPa which can maximally be measured at PTB, the pressure scale is realized with a manganin resistance manometer whose properties are determined from the calibration with the 1 GPa pressure balance. This type of extrapolation leads to clearly higher relative uncertainties of up to $4 \cdot 10^{-3}$ for pressures $p > 1$ GPa.

6 Outlook

For most applications, the internationally recognized pressure measurement capabilities [12] offered by PTB are completely sufficient. Two new challenges which pressure metrology has had to meet in the past few years are the extension of the measurement range up to 1.6 GPa, in which newly developed precision pressure transducers which are required by industry are to be calibrated, and the reduction of the relative standard uncertainty of the absolute pressure measurement in the range from 1 MPa to 7 MPa to 10^{-6} which is necessary for a redefinition of the Boltzmann constant and a new thermodynamic definition of the temperature unit Kelvin [13]. To solve the two tasks, new pressure standards must be developed which will work in accordance with the pressure balance principle [14].

Literature

- [1] Decker D.L., Bassett W.A., Merrill L., Hall H.T., Barnett J.D.: J. Phys. Chem. Ref. Data, 1 (1972), pp. 773–836
- [2] ISO 1000-1973, DIN 1301, www.bipm.org
- [3] Jousten K.: PTB-Mitteilungen 118 (2008), 3, pp. 175–178
- [4] High Pressure Measurement Techniques, ed. by G.N. Peggs, London, N.Y., Applied Science Publishers, 1983
- [5] Pavese F., Molinar G.: Modern gas-based temperature and pressure measurements, N.Y., Plenum Press, 1992
- [6] Tilford C.R.: Metrologia 30 (1993/94), pp. 545–552
- [7] Dadson R.S., Lewis S.L., Peggs G.N.: The pressure balance: theory and practice, London, HMSO, 1982
- [8] Jusko O., Bosse H., Lüdicke F.: High precision 3D-calibration of cylindrical standards, in: Advanced Mathematical Tools in Metrology III (ed. by P. Ciarlina, M.G. Cox, F. Pavese and D. Richter), Singapore, World Scientific Publishing Company, 1997, pp. 186–194
- [9] Sabuga W., Molinar G., Buonanno G., Esward T., Legras J.C., Yagmur L.: Metrologia 43 (2006), pp. 311–325
- [10] Jäger J., Sabuga W., Wassmann D.: Metrologia 36 (1999), pp. 541–544
- [11] Jäger J., Schoppa G., Schultz W.: The standard instruments of the PTB for the 1 GPa range of pressure measurement, PTB-Report W-66, Braunschweig, October 1996
- [12] <http://kcdb.bipm.org/AppendixC/search.asp?met=M&reset=1>
- [13] Fellmuth B., Gaiser Ch., Fischer J.: Meas. Sci. Technol. 17 (2006), pp. 145–159
- [14] Sabuga W.: MAPAN – J. Metrol. Soc. India, 22 (2007), pp. 3–11

The Quantity of “Nothing”: Measuring the Vacuum

Karl Jousten*

1 Introduction

Under the term „vacuum“, often space without any material particles whatsoever is understood. This is more accurately known as the ideal or absolute vacuum (Figure 1). Although in our universe totally empty space is not possible [1] – energy is present everywhere and space containing energy is created only from the balance between material and antimaterial – there wouldn't actually be much for metrologists to measure in an ideal vacuum. This is different, however, in the case of the vacuum as defined for technical purposes (DIN 28400): Vacuum is the condition of a gas when its pressure is less than the smallest pressure of 300 hPa occurring on the surface of the Earth. The measuring scale reaches from this pressure down to 10^{-12} Pa.

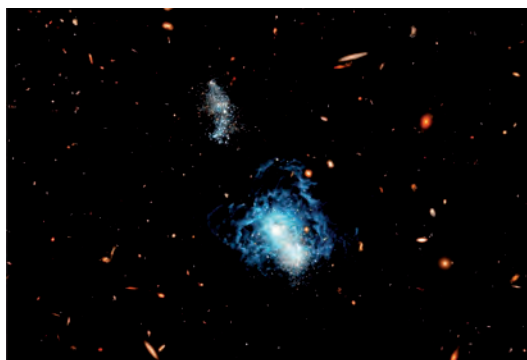

Figure 1:

Between the galaxies, there are macroscopic spaces in the cm^3 range which are particle-free (ideal vacuum). Foto StScI-PrC07-35a NASA/ESA/Hubble Space Telescope.

The vacuum achieved economic importance for the first time in the manufacture of the first light bulbs in 1879 by Edison (Figure 2). The oxygen of the atmosphere would have destroyed the filament within a short period of operation. Many fields of application have since been added to the lighting industry: The microelectronics industry is to be mentioned in first place thereby, because it purchases approx.

40 % of the products manufactured worldwide for the vacuum. The coating industry is a further significant branch. The products in question hereby are hardening coatings (e. g. tools, bearings), functional coatings (CD, DVD, magnetic memories, eyeglasses, lenses, architectural glass, PET bottles, foil metallization, textiles) or also decorative coatings. Further important examples of the applications of the vacuum technology are the automobile industry (leak test of rims and motors, filling of brake and air conditioning systems), metallurgy, the chemical and pharmaceutical industry, the electrical industry (transceiver tubes) and the aerospace industry.

Also, almost everywhere in physical research, a defined vacuum environment is required.

* Dr. Karl Jousten, Head of the Working Group „Vacuum Metrology“, e-mail: karl.jousten@ptb.de

Table 1:

The individual pressure ranges of the vacuum. The smallest pressure created so far at room temperature in the laboratory is 10^{-12} Pa.

	Pressure in Pa	Particle density in cm^{-3}	Mean free path length in m
Low vacuum	$100 \dots 10^5$	$10^{16} \dots 10^{19}$	$10^{-4} \dots 10^{-7}$
Fine vacuum	$0,1 \dots 100$	$10^{13} \dots 10^{16}$	$10^{-1} \dots 10^{-4}$
High vacuum	$10^{-5} \dots 0,1$	$10^9 \dots 10^{13}$	$10^{-1} \dots 10^3$
Ultra-high vacuum	$< 10^{-5}$	$< 10^9$	$> 10^3$

In the 20th century, particularly in the second half, due to this requirement a strong vacuum industry developed which provides the needed vacuum pumps, chambers, active and passive components, and the corresponding measuring technology. Thereby, the individual vacuum ranges (Table 1) which encompass 17 orders of magnitude of pressure require quite different techniques. Also, the vacuum measurement technique requires many different measuring principles in order to be able to cover this large measuring range.

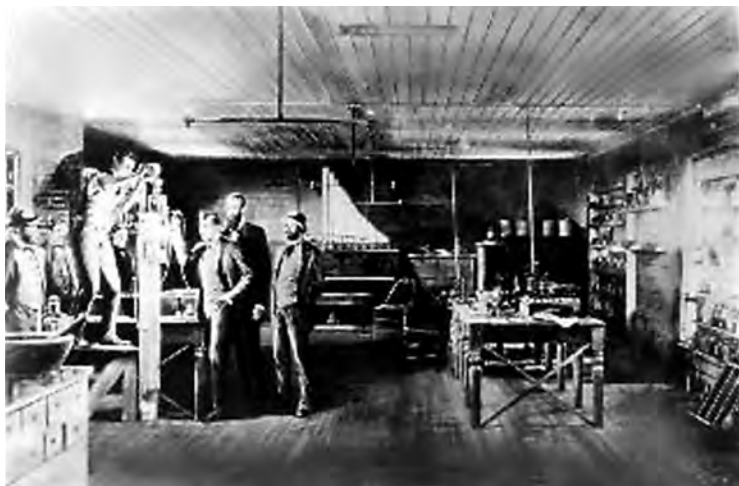

Figure 2:

The economic importance of the vacuum industry began with Edison's light bulb production in Menlo Park in 1879. The man standing elevated is pouring mercury into a Sprengel pump to evacuate the light bulb.

2 Vacuum measurement

The scale of the pressure measurement in the vacuum is based on the definitive equation of the pressure p as the normal force F per surface A :

$$p = \frac{F}{A} \quad (1)$$

Vacuum measuring devices which measure a force directly or indirectly can be constructed inexpensively in a measuring range down to approx. 100 Pa. The principle of the aneroid manometers rests on the deflection of a membrane which closes an evacuated metal capsule. The membrane is indented by the acting external pressure and the indentation is transmitted to an indicator [2]. Also devices which measure the deflection of a membrane piezoresistively or with a piezo crystal are conventional and inexpensive.

If one wants to measure accurately via the mechanical force effect of pressure also below 100 Pa, one must enlist the assistance of sensitive electrical methods. In the case of capacitive measurement, the membrane deflected under a differential pressure is formed as the electrode of a condenser, which in turn is part of an oscillating circuit [3]. With this measuring method, it is possible to measure deflections of a membrane down to 0.5 nm. The resolution of these devices is 10^{-4} Pa. With it, however, also the end of vacuum measurement via a pressure measurement has been reached.

Below 100 Pa, it is considerably less expensive to measure the heat conductance of a gas from a heated element. In the fine vacuum and lower, the heat conductance is linearly proportional to the gas density. In the high vacuum, however, radiation effects dominate such that the lower measuring threshold is approx. 0.1 Pa.

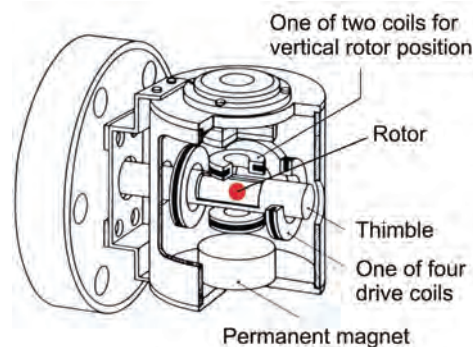

Figure 3:

Schematic drawing of a gas friction vacuum meter. The frequency reduction of a magnetically suspended, rotating sphere (red) is measured.

The spinning rotor gauge, very popular with calibration laboratories because of its stability (Figure 3), measures the frequency reduction of the rotation of a sphere magnetically suspended in the vacuum [4]. It is decelerated as a result of momentum transfer to the gas particles.

In the high and ultra-high vacuum, the pressure unit is no longer a sensible measurement quantity. The gas particles have such a large medium free path length that they no longer collide with each other but rather only travel from wall to wall of the vacuum system. Also, the force effect of a pressure is no longer measurable. A more sensible measurand is the gas density. So as not to change the scale, the gas density is measured and converted into a pressure quantity by application of the ideal gas law.

The gas density is measured by ionising the gas particles. The measured ion current is proportional to the gas density and thus to the pressure. The ionisation is carried out either by a discharge (Penning and magnetron vacuum gauges) or by means of fast electrons (hot-cathode-ionisation vacuum gauge).

For further vacuum measuring devices and more details, please refer to the additional literature [2].

3 Calibration of vacuum measuring devices

There is no vacuum measuring device with which it would be possible to obtain the pressure with sufficient accuracy from the measuring signal via a physical equation. Either the physical processes are not definable in detail or the parameters are not sufficiently known. The spinning rotor gauge comes closest to an absolute physical pressure determination. In this case, merely the effective accommodation coefficient of the gas particles on the sphere's surface must be determined by calibration. The indicators of all vacuum measuring devices must be individually calibrated by the manufacturer and, in part, also linearised.

Thus via the calibration hierarchy, the traceability to the derived SI unit of pressure must be ensured for all vacuum measuring devices.

4 Traceability to the SI units

The pressure scale in the vacuum is traced back via the definitive equation (1) and the use of a mercury manometer or a piston manometer to the SI units of mass, length and time [5]. Figure 4 shows how the scale of the vacuum pressures is continued at the PTB to include smaller pressures. By means of the primary standards of the static and continuous expansion process, the scale is realized down to 10^{-9} Pa.

5 Primary standards for the vacuum

In the static expansion process, the Boyle-Mariotte law is used: The product of pressure and volume is constant at constant temperature for an enclosed gas quantity. That means that when gas is enclosed in a small volume under relatively high pressure and subsequently expanded into a considerably larger volume, evacuated beforehand, then the pressure will be reduced in accordance with the volume ratio. In the general case, it is not possible to create the exact same temperature conditions for the two volumes and the connecting pipe between them, such that instead of the Boyle-Mariotte law, the ideal gas law is used. If p_1 , V_1 and T_1 denote pressure, volume and temperature before the expansion, p_2 the pressure afterwards, and V_2 the volume into which the expansion takes place, including the connecting pipes, then the following applies:

$$p_2 = p_1 \frac{V_1}{V_1 + V_2} \frac{T_2}{T_1} \quad (2)$$

The so-called expansion ratio $V_1/(V_1+V_2)$ is the crucial parameter of an expansion system and must be determined with the greatest possible accuracy [6], [7]. A part of the gas expanded to the pressure p_2 can in turn serve as the starting point for another expansion. With such multiple expansions carried out in succession, pressures down to approx. 10^{-2} Pa can be realized, in special cases, even down to 10^{-6} Pa.

The outgassing of the vacuum walls and the adsorption of the calibration gas limit the applicability of the process to low pressures.

Therefore in the case of smaller pressures, the continuous expansion process is used: The calibration gas is continuously pumped through two orifices, strongly differing in size (conductance $C_1 \ll C_2$), into a vacuum pump. If there is no source or drain of the gas between the orifices, then the continuum equation applies, i.e. the pV -throughput must be the same for both orifices. If p_1 denotes the pressure before the first orifice, p_2 the pressure between the orifices, and p_3 the

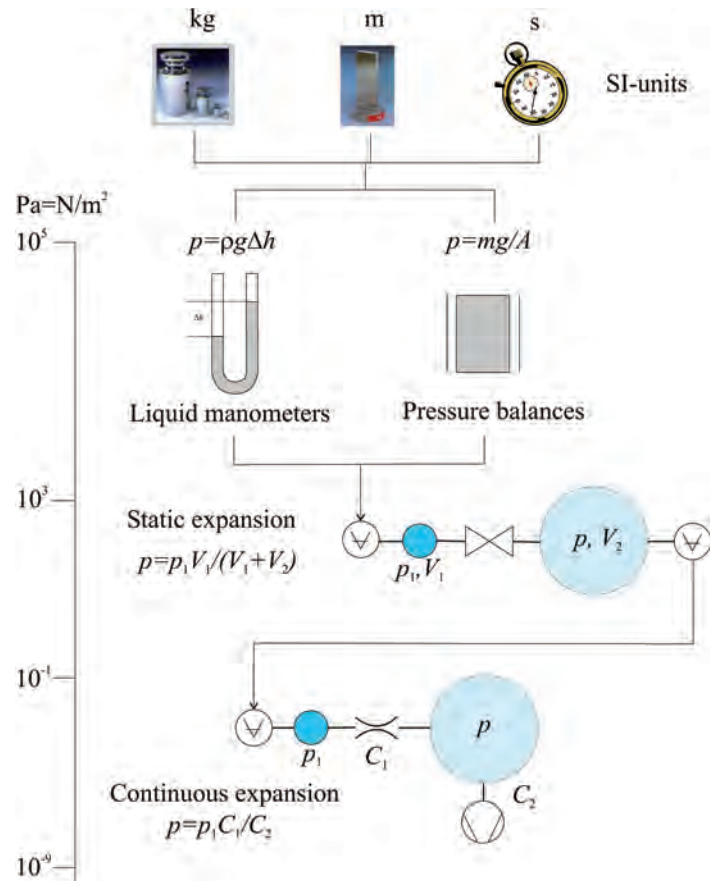

Figure 4:

Overview of the traceability of the unit of pressure in the vacuum range to the SI units

pressure after the second orifice, then under isothermic conditions the following applies:

$$(p_1 - p_2)C_1 = (p_2 - p_3)C_2 \quad (3)$$

Since p_2 is very small compared to p_1 , likewise p_3 compared to p_2 , the following applies in a good approximation:

$$p_2 = p_1 \frac{C_1}{C_2} \quad (4)$$

Thus, whereas in the case of the static expansion process two volumes greatly differing in size are used, the pressure reduction in the case of the continuous expansion process occurs by two orifices differing in size. The initial pressure p_1 is reduced in accordance with the orifice ratio to the pressure p_2 . This pressure p_2 is the desired calibration pressure.

In a primary standard in accordance with the continuous expansion process, the orifice C_1 is chosen to be very small (PTB: 10^{-6} l/s) compared with C_2 (100 l/s), such that the pressure reduction is correspondingly large.

The storage tank for p_1 as well as the orifice of the pressure-dependent conductance C_1 are combined in a so-called gas flow meter. This produces a gas flow, whose value is known by the measurement of p_1 , C_1 and the temperature.

The lower measurement threshold is determined by the smallest pressure p_1 at which the conductance C_1 can still be measured with sufficient accuracy. This is the case at approx. 10 Pa, such that $p_2 = 10^{-7}$ Pa is the lower measurement threshold.

In the PTB this was reduced by a factor of 100 through the use of a flow divider (chamber, center, in Figure 5) [8]. The flow divider is a chamber with two orifices differing by a factor of 100 in the conductance. The gas flowing into

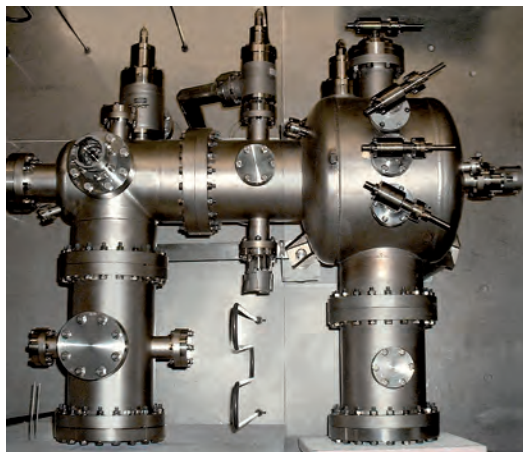

Figure 5:
The primary standard
CE3 of the PTB in accordance with the continuous expansion.

this chamber from the gas dosing system is conducted into two different calibration chambers via the orifices. The chamber located behind the smaller orifice reaches a calibration pressure of down to 10^{-9} Pa.

The uncertainties of the realized pressures lie between 0.1 % and 0.3 % in the static expansion process, between 0.4 % and 2 % in the continuous expansion process.

The pressure transfer to calibration laboratories is carried out by the calibration of transportable vacuum measuring devices of highest accuracy (secondary standards).

6 Secondary standards for the vacuum

Modern pressure balances which measure by means of a force meter (balance) the force exerted by the pressure on a non-rotating piston, can be used down to 10 Pa as secondary standard and under certain circumstances, even as primary standard.

They are quite large and expensive, however, and instead, in the range from 0.1 Pa to 100 kPa, capacitive membrane vacuum meters are mainly used. Above 1 kPa, also high-quality quartz Bourdon spirals and oscillating quartz manometers can be used [2].

From 0.1 Pa to 10^{-4} Pa, the spinning rotor gauge is used as secondary standard and in the case of still smaller pressures, the hot cathode ionisation vacuum meter is used.

7 Future challenges

Vacuum technology including vacuum measurement technology has attained a high level of maturity which satisfies many users. Nevertheless, there are critical points: Many vacuum-technological processes in the industry proceed extremely rapidly for economic reasons. The cycle time of CD metallisation, i.e. the evacuation, coating and re-aerating amount to, depending on the metalliser, between 1.5 s and 2.5 s. In a period of less than 0.7 s, the pressure changes by a factor of 10^4 . To what extent the vacuum measuring devices can follow this dynamics was only estimated so far, but whether their calibration is still accurate in the case of such dynamics has never been investigated. Optical methods could in future play a role here.

These could also play an important role in the case of partial pressure measurement and its traceability. The gas purity of a process gas and its composition is often just as important as the total pressure. The currently used quadrupole mass spectrometers for determining the partial pressure have considerable deficits with regard to their calibratability [9]. Optical methods promise good prospects here [10, 11], but still have to be investigated.

Literature

- [1] Genz, H.: Nichts als das Nichts – Die Physik des Vakuums, Wiley-VCH, 2004, 266 S., ISBN 3-527-40319-1
- [2] Jousten, K. (ed.): Handbook of Vacuum Technology, Wiley-VCH, 2008, ISBN 978-3-527-40723-1
- [3] Sullivan, J. J.: J. Vac. Sci. Technol. **A 3** (1985), 1721–1730
- [4] Fremerey, J.K.: Vacuum **32** (1982), pp. 685–690
- [5] Sabuga, W.: PTB-Mitt. 118 (2008) pp. 170–174
- [6] Jitschin, W., Migwi, J.K., und Grosse, G.: Vacuum **40** (1990), pp. 293–304
- [7] Jousten, K., Aranda Contreras, V., and Röhl, P.: Vacuum **52** (1999), pp. 491–499
- [8] Jousten, K., Menzer, H., Wandrey, D., Niepraschk, R.: Metrologia **36** (1999), pp. 493–497
- [9] Lieszkovsky, L., Filipelli, A. R. and Tilford, C. R.: J. Vac. Sci. Technol. **A 8** (1990), p. 3838
- [10] Lanzinger, E., Jousten, K., Kühne, M.: Vacuum **51** (1998), pp. 47–51
- [11] Padilla-Viquez, G., Koelliker-Delgado, J., Werhahn, O., Jousten, K., and Schiel, D.: Proceedings CPEM 2006, IEEE transactions on instrumentation and measurement, **56** (2) (2007), pp. 529–533